

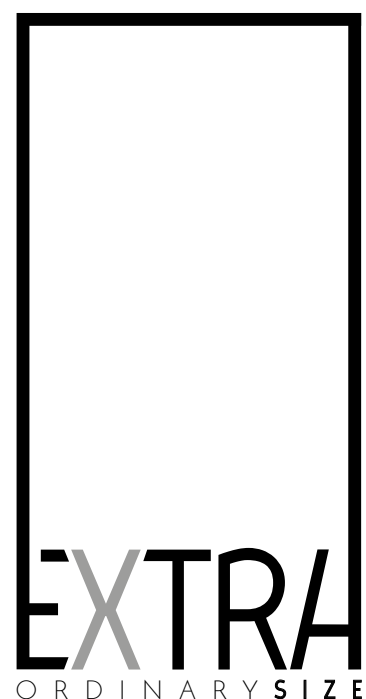

EXTRA
ORDINARY SIZE





EXTRA ORDINARY SIZE

L'ORIGINE È IN UNA LASTRA, LA PIÙ GRANDE AL MONDO.

L'evoluzione è nell'ingegno, nella creatività, nella versatilità che dà vita ai progetti più ambiziosi. Con **EXTRAORDINARYSIZE** il gres porcellanato è il nuovo alleato per ogni tipo di applicazione. Anche le più "extra".

THE ORIGIN OF THIS LINE LIES IN THE TILE, WHICH IS THE LARGEST EVER TO BE MADE WORLDWIDE.

The evolution lies in the engineering, the creativity, and the versatility, which combine to give life to the most ambitious of designs. With the **EXTRAORDINARYSIZE** option, porcelain stoneware has become the latest, essential material for all applications. Even the most 'extra' jobs.

L'ORIGINE EST UNE DALLE, LA PLUS GRANDE DALLE DU MONDE.

L'évolution est dans le génie, dans la créativité, dans la polyvalence qui donnent vie aux projets les plus ambitieux. Avec **EXTRAORDINARYSIZE** le grès cérame est votre nouvel allié pour tout type d'application, même les applications "extra".

DER URSPRUNG IST EINE PLATTE, DIE GRÖSSTE AUF DER WELT.

Die Evolution befindet sich im Talent, in der Kreativität, in der Vielseitigkeit, welche die ehrgeizigsten Projekte ins Leben rufen. In **EXTRAORDINARYSIZE** ist das Feinsteinzeug der neue Verbündete für alle Anwendungsarten, selbst für die "ungewöhnlichsten".

EL ORIGEN ES UNA PLANCHA DE CERÁMICA, LA MÁS GRANDE DEL MUNDO.

La evolución está en el ingenio, en la creatividad, en la versatilidad que da vida a los proyectos más ambiciosos. Con **EXTRAORDINARYSIZE** el gres porcelánico es el nuevo aliado para todo tipo de aplicaciones. Hasta las más "especiales".

ИСТОКИ - В ПЛИТЕ, САМОЙ БОЛЬШОЙ В МИРЕ.

Эволюция - в гениальности, в креативности, в универсальности, которая вдыхает жизнь в самые амбициозные проекты. Благодаря **EXTRAORDINARYSIZE** керамогранит превращается в нового союзника для применений любого типа. Даже самых крупных.

源于世界上最大的瓷板。

演变在于智慧、创造力和活力，它们造就了最珍贵的项目。

有了**EXTRAORDINARYSIZE**产品，瓷砖成为每项应用的新伙伴，包括最“特殊”的应用。



I N D E X

06 / PLUS

16 / EXTRA APPLICATIONS

WALL & FLOOR

17 / PAVIMENTO E RIVESTIMENTO

BUSINESS TO BUSINESS

43 / CONTRACT

67 / FACCIATE VENTILATE E INCOLLATE

71 / INDUSTRIA NAVALE

FURNITURE AND DESIGN

73 / TOP E RIVESTIMENTI COORDINATI

77 / ARREDAMENTO E DESIGN

83 / PORTE E ANTE

87 / EXTRA COLORS

88 / MARMI

102 / ONICI

104 / PIETRE&GRANITI

106 / CONTEMPORANEI

124 / TECHNICAL FEATURES



100% DESIGN
AND PRODUCTION
OF ITALY



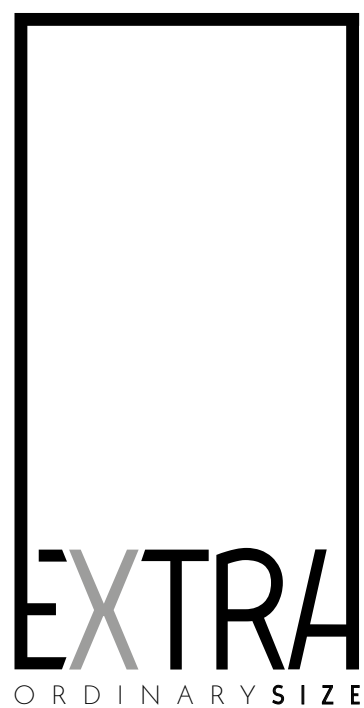

LASTRE IN GRES PORCELLANATO PRESSATE A SECCO

Dry-pressed porcelain stoneware slabs.
 Dalles en grès cérame pressées à sec.
 Trockengepresste Platten aus Feinsteinzeug.
 Planchas en gres porcelánico prensadas en seco.
 Керамогранитные плиты сухого прессования.
 干压陶瓷砖。

Spessore. 6mm - 10mm

Thickness.
 Epaisseur.
 Stärke.
 Espesor.
 Толщина.
 厚度。

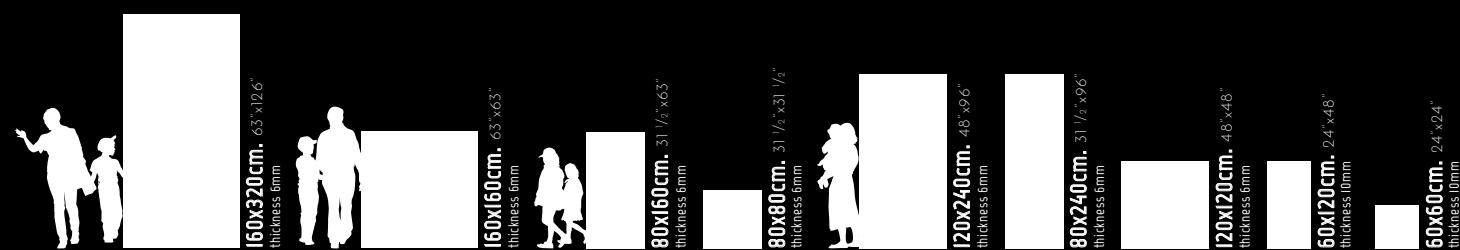

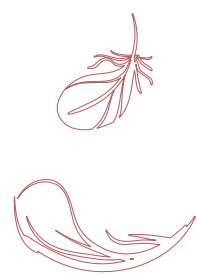

EXTRALIGHT

Con soli 6 mm di spessore, le lastre **EXTRAORDINARYSIZE** sono facili da spostare e leggere da movimentare, anche nei grandi formati.

The slabs are easy to move and handle as they are only 6 mm thick, ensuring lightness despite their large size.

Les plaques sont faciles à déplacer et à manutentionner, grâce à leur épaisseur de 6 mm seulement qui garantit légèreté malgré, les grandes dimensions.

Mit nur 6 mm Stärke lassen sich die Platten EXTRAORDINARYSIZE auch in den großen Formaten mühelos verschieben und leicht transportieren.

Con solo 6 mm de espesor, las losas EXTRAORDINARYSIZE son fáciles de desplazar y mover, incluidos los grandes formatos.

Плиты легко можно перемещать и обрабатывать благодаря небольшой толщине всего лишь 6 мм: такая толщина обеспечивает их легкость, несмотря на большие размеры.

超轻系列板材由于其厚度仅6mm保证了它的轻度，尽管面积很大也易于搬运。

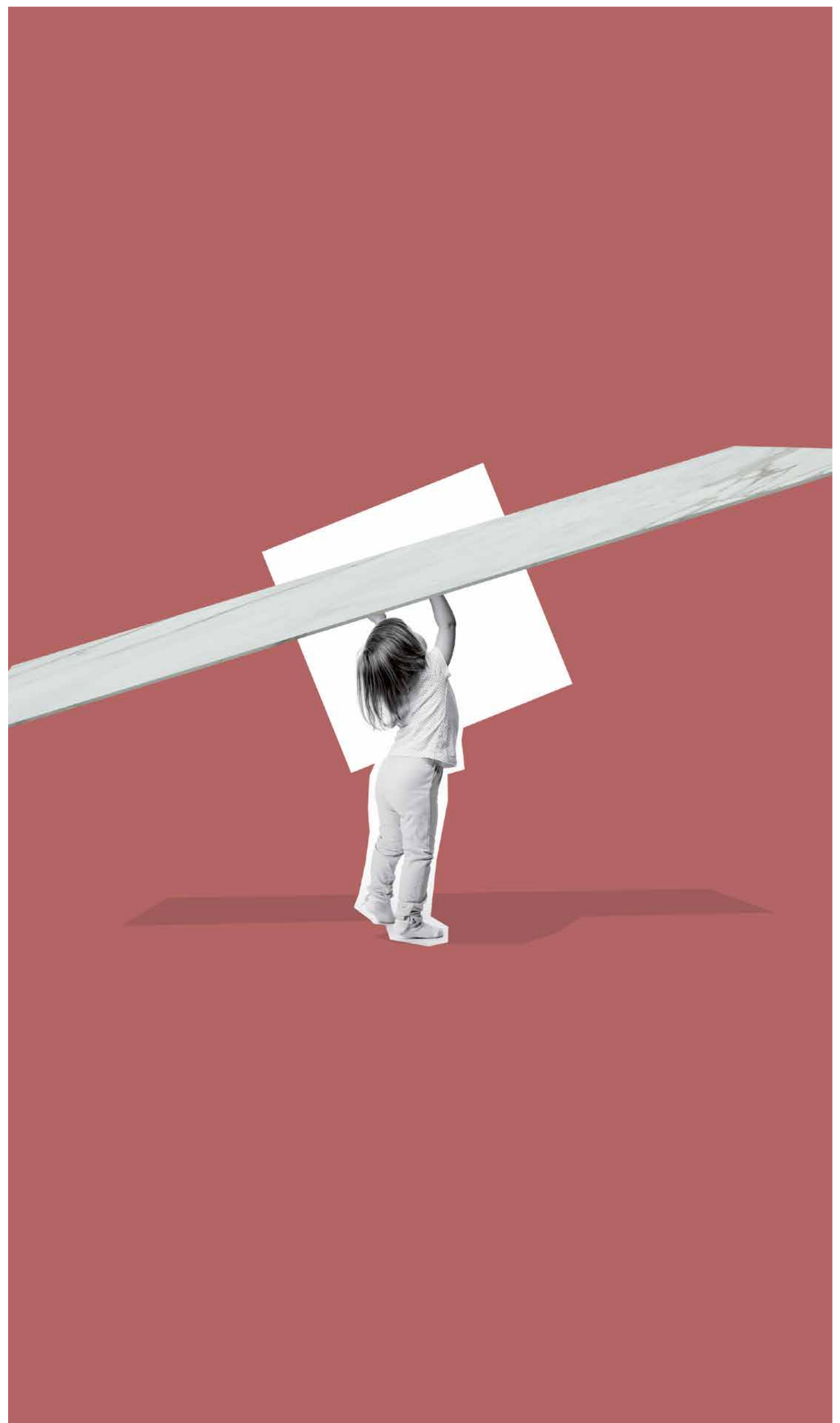



EXTRA SIZE

Tanti formati, dal più grande presente sul mercato di **160x320 cm** in **6 mm** di spessore, fino al più tradizionale **60x60 cm** in **10 mm**, per un progetto completo e versatile.

A complete and versatile project: from the largest size available on the ceramics market, 160x320 cm and 6 mm thick, down to the most common size, 60x60 cm, 10 mm thick, passing through a full range of intermediate sizes.

Un projet complet et polyvalent : du plus grand format disponible sur le marché de la céramique, le 160x320 cm de 6 mm d'épaisseur jusqu'au format le plus courant le 60x60 cm de 10 mm d'épaisseur, en passant par une gamme complète de formats intermédiaires.

Ein umfassendes und vielseitiges Projekt: Von den größten auf dem Keramikmarkt zu findende Formaten, 160x320 cm mit 6 mm Stärke, über das weit verbreitete Format, 60x60 cm mit 10 mm Stärke, bis hin zur kompletten Serie mittlerer Formate.

Un proyecto completo y versátil: desde el formato más grande disponible en el mercado cerámico, el 160x320 cm en 6 mm de espesor, hasta el formato más difundido, el 60x60 cm en 10 mm de espesor, pasando por una gama completa de formatos intermedios.

Полный и универсальный проект: от максимального формата, имеющегося на рынке, размерами 160x320 см и толщиной 6 мм, до самого распространенного формата 60x60 см толщиной 10 мм, включая полный ассортимент промежуточных форматов.

该系列涵盖范围广、用途多：从陶瓷市场最大规格的160x320cm（厚度6mm）到最常见的60x60cm（厚度10mm），其中自然也包括中间规格。





EXTRA STYLISH

Ispirazioni differenti definiscono il design ceramico di ogni collezione, personalizzando ogni tipo di ambiente con la massima resa estetica.

The ceramic design interprets different inspirations, ensuring maximum aesthetic appeal in any type of environment and giving each its own style.

Le design céramique interprète différentes inspirations, en garantissant le meilleur rendu esthétique quel que soit l'espace et en imprimant à chacun un style personnel.

Das Keramikdesign fasst unterschiedlichste Inspirationen auf, die den Räumen Ästhetik und einen ganz eigenen Stil verleihen.

El diseño cerámico interpreta distintas inspiraciones, garantizando el máximo rendimiento estético en cada tipo de ambiente y atribuyendo a cada uno su propio estilo.

Дизайн керамики интерпретирует различные идеи и обеспечивает максимальный эстетический эффект в помещении любого типа, создавая в каждом собственный стиль.

该系列的陶瓷设计灵感来自多方面，在任何使用环境中都能保证最大的美观效果同时展现自己的风格。



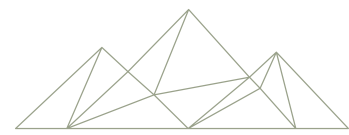

EXTRA DIFFERENT

Ogni serie e ogni colore possono essere declinati in grafiche molteplici e differenti tra loro grazie alla tecnologia di decorazione digitale ceramica Inkjet, per effetti estetici di pavimenti e rivestimenti sempre unici e originali.

The Inkjet ceramic technology allows for any collection and colour, a high number of different graphics, for an aesthetic effect of the flooring and cladding that is always varied and never repetitive.

La technologie céramique Inkjet, permet de réaliser pour chaque collection et chaque couleur, un nombre élevé de rendus graphiques différents, en apportant ainsi un effet esthétique au revêtement de sol et aux autres revêtements, toujours varié et jamais répétitif.

Dank der Inkjet Keramiktechnologie kann man für alle Kollektionen und Farben zahlreiche unterschiedliche Grafiken kreieren und für den Boden- und Wandbeläge vielfältige und einzigartige ästhetische Effekte erzielen.

La tecnología cerámica Inkjet permite realizar, para cada colección y color, un elevado número de diferentes diseños gráficos, para un efecto estético del pavimento y del revestimiento siempre diferente y nunca repetitivo.

Технология Inkjet позволяет реализовать, для каждой коллекции и цвета, большое количество различных графических вариантов и обеспечить разнообразнейшее и всегда неповторимое эстетическое оформление пола или облицовки.

使用Inkjet陶瓷技术，可以生产出不同风格和颜色、数量庞大不同图案的产品，既保证地板和墙面的美观又保证绝不重复。





EXTRA TAILORED

È dai grandi formati che nascono tagli e forme di ogni dimensione, realizzate su misura per offrire nuove opportunità compositive e ampliare gli ambiti di utilizzo delle lastre: dai pavimenti ai rivestimenti di pareti verticali, di mobili, tavoli, piani di lavoro, ante, yacht e navi da crociera.

With large sizes, you can make cuts of any shape and size, to further extend the possibilities of use of the slab covering floors, walls, furniture, tables and doors.

Avec les grands formats on peut réaliser des coupes de toute forme et toute dimension, pour élargir ultérieurement la gamme d'utilisations de la plaque, en partant du revêtement de sol pour arriver au revêtement de parois, meubles, tables, plans et portes.

Mit Großformaten sind beliebig große Schnitte in unterschiedlichsten Formen möglich und die Anwendungsmöglichkeiten der Platte werden noch umfangreicher, von Böden bis hin zur Verkleidung von Wänden, Möbeln, Tischen, Flächen und Türen.

Con los grandes formatos se pueden realizar cortes de cualquier forma y dimensión para ampliar ulteriormente las posibilidades de uso de la losa, que abarca desde el pavimento hasta llegar al revestimiento de paredes, muebles, mesas, superficies y puertas.

Из больших форматов всегда можно создавать меньшие форматы любых форм и размеров, все более расширяя возможности применения плиты: от пола до облицовки стен, мебели, поверхностей, створок.

采用大规格的板材，可以随意切割成各种形状和尺寸的板材，进一步扩大板材的应用范围，可应用在地板、墙面装饰、家具、桌面、平台和窗板。



EXTRA APPLICATIONS

PAVIMENTO E RIVESTIMENTO

Floor and covering
 Revêtement sols et murs
 Boden und Verkleidungen
 Pavimento y revestimiento
 Полы и облицовка
 地板及墙面

Nessun limite di forma o dimensione per i pavimenti e i rivestimenti realizzati con le grandi lastre di 160x320 cm e i suoi numerosi sottomultipli, perfette per arredare ogni tipo di ambiente con uno stile sempre personale e importante. L'avanguardia tecnologica della stampa digitale ceramica inkjet, infatti, consente di riprodurre sul gres porcellanato ogni tipo di grafica e ispirazione, rendendo ogni collezione unica e originale.

With the 160x320 cm large slabs and the many smaller sizes, you can create tiled floors and walls that are unique in the world. Using the latest generation inkjet technology, stone and marble graphics are faithfully reproduced on porcelain stoneware, in endless versions, differing in colour and size.

Avec les grandes plaques 160x320 cm et les nombreux sous-formats, on peut réaliser des revêtements de sols et muraux uniques au monde grâce à la technologie inkjet de dernière génération, qui permet de reproduire fidèlement sur le grès cérame des collections avec de nombreuses formes graphiques différentes pour chaque couleur et format.

Mit den großen Platten, 160x320 cm und den zahlreichen Unterformaten kann man weltweit einzigartige Böden und Wandbeläge anfertigen, dank der Inkjet-Technologie der neusten Generation, mit der man auf dem Feinsteinzeug Kollektionen mit zahlreichen in der Farbe und im Format unterschiedlichen Motiven getreu reproduzieren kann.

Con las grandes placas de 160x320 cm y muchos subformatos se pueden realizar pavimentos y revestimientos únicos en el mundo gracias a la tecnología inkjet de última generación, que permite producir fielmente en el gres porcelánico colecciones con innumerables gráficas diferentes por cada color y formato.

Из больших плит 160x320 см и множества производных форматов можно реализовать неповторимые полы и облицовки благодаря струйной технологии печати последнего поколения, которая позволяет точно воспроизвести на керамограните коллекции с бесконечным разнообразием графики для любого цвета и формата.

凭借160x320 cm的大板块以及小板块，可以获得世界上独一无二的地板与墙，其秘密正在于新一代喷墨技术，它能有效地在陶瓷上复制各类系列，通过颜色形状的变动产生大量不同的图案。



CONTEMPORANEI DISTRICTTORTORA 160x160 - 63"x63" NAT. RET.



CONTEMPORANEI ABSOLUTE WHITE 120x120 - 48"x48" NAT. RET.
 RIVESTIMENTO E ARREDI/WALL AND FURNITURE: ABSOLUTE BLACK NAT. RET. / LAP. RET.



MARMIBARDIGLIO CENERE 160x320 - 63x126" LAP. RET.



MARMISTATUARIO SLAB A - B 160x320 - 63"x126" LAP. RET.
 MARMISTATUARIO 160x320 - 63"x126" LAP. RET. / 160x160 - 63"x63" LAP. RET.



MARMILASA 160x320 - 63"x126" LAP. RET.
TOP MARMILAZUL MACAUBA LAP. RET.



CONTEMPORANEI SKYLINEBEIGE 160x320 - 63"x126" NAT. RET.



ONICI AESTHETICAHEGEL 160x160 - 63"x63" LAP.RET. / WILDE 160x320 - 63"x126" LAP.RET.

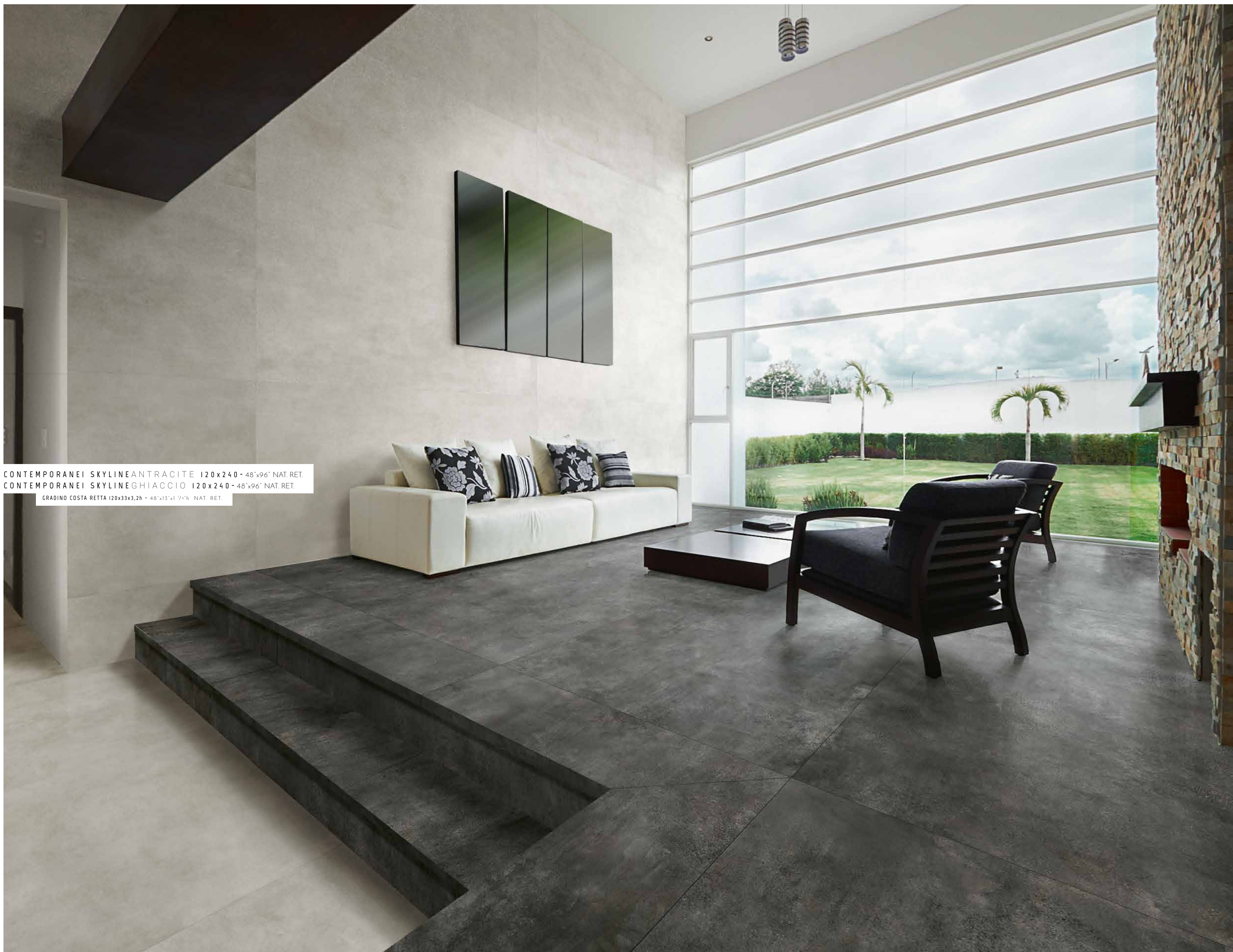

CONTEMPORANEI SKYLINE ANTRACITE 120x240 - 48"x96" NAT. RET.
 CONTEMPORANEI SKYLINE GHIACCIO 120x240 - 48"x96" NAT. RET.
 GRADINO COSTA RETTA 120x33x3,2h - 48"x13"x1 1/4" NAT. RET.



MARMIBIANCO BERNINI 80x80 - 31 1/2"x31 1/2" LAP. RET. . . 80x160 - 31 1/2"x63" LAP. RET.



PIETRE&GRANITI COPACABANAEMPEROR 60x120 - 24"x48" LAP. RET.
 MOBILETTO RIVESTITO CON MARMI CALACATTA LAP. RET.
 FORNITURE CLAD WITH MARMI CALACATTA LAP. RET.

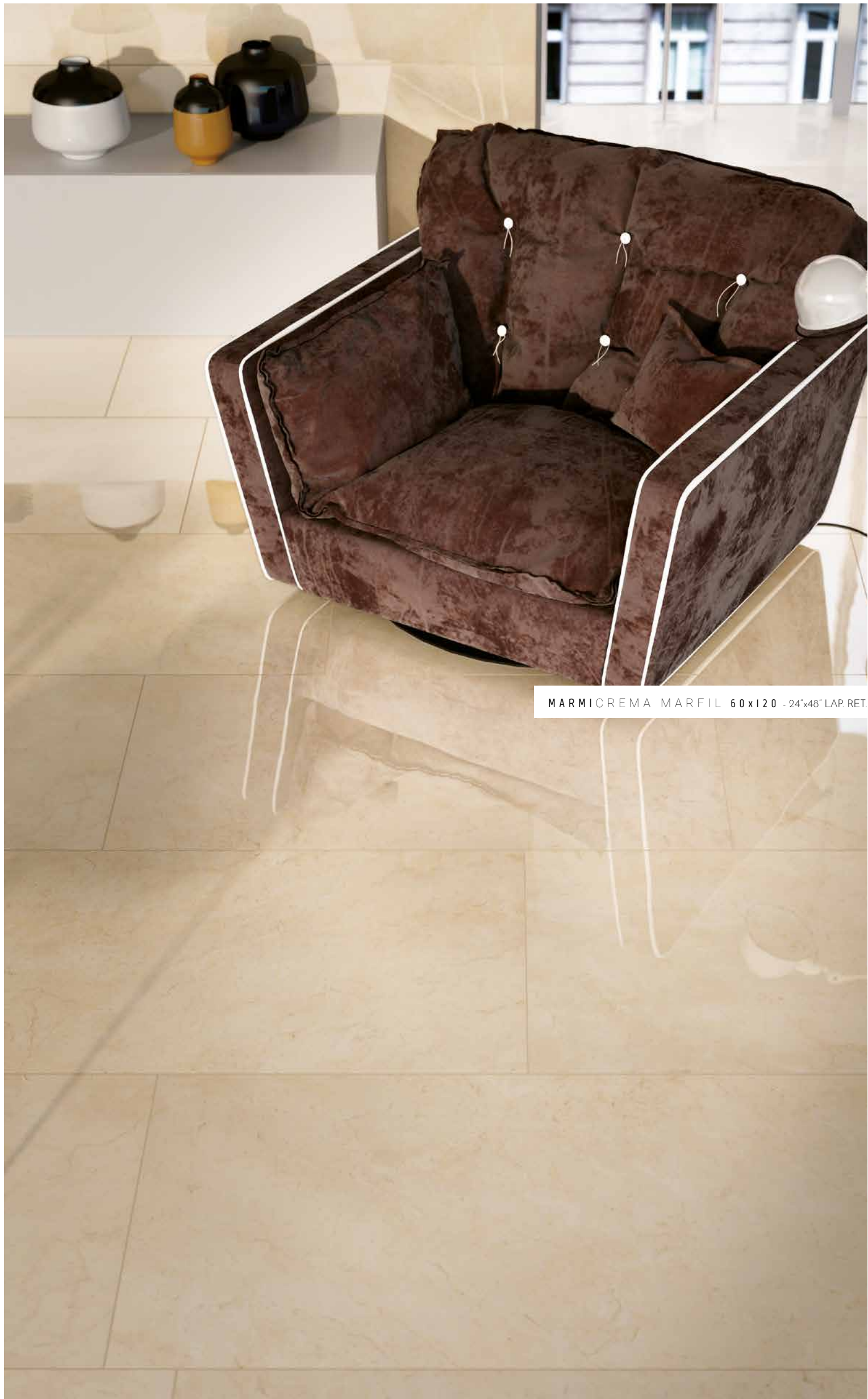

MARMICREMA MARFIL 60x120 - 24"x48" LAP. RET.



PIETRE&GRANITI COPACABANADUKE 80x160 - 31 1/2"x63" NAT. RET.



PIETRE&GRANITI / COPACABANA EMPEROR

CONTRACT

Контрактные поставки
协议

Le caratteristiche di leggerezza e resistenza delle lastre in gres porcellanato con spessore di 6 e 10 mm rendono **EXTRAORDINARYSIZE** la soluzione ideale per i progetti del contract, garantendo le migliori performances estetiche e tecnologiche.

EXTRAORDINARYSIZE is a line of 6 and 10 mm-thick porcelain stoneware tiles which is ideal when the job in hand has specific technical requirements such as lightness and strength. It is particularly useful in large-scale projects.

EXTRAORDINARYSIZE est un projet de plaques d'une épaisseur de 6 et 10 mm en grès cérame particulièrement recommandées pour des exigences spécifiques techniques comme la légèreté et la résistance, les applications du secteur "gros marchés".

EXTRAORDINARYSIZE ist ein Projekt von Platten aus Feinsteinzeug mit einer Stärke von 6 bis 10 mm. Dieses Produkt passt sich besonders gut an die spezifischen technischen Anforderungen, wie Leichtigkeit und Beständigkeit, im "contract"-Bereich an.

EXTRAORDINARYSIZE es un proyecto de placas en 6 y 10 mm de espesor en gres porcelánico, lo que hace que el producto sea particularmente adecuado según los específicos requerimientos técnicos y también como ligereza y resistencia para las aplicaciones del sector "contract".

EXTRAORDINARYSIZE – это проект керамогранитных плит толщиной 6 и 10 мм, что делает эту продукцию особенно пригодной для удовлетворения таких специальных технических требований, как легкость и прочность, в сфере контрактных поставок.

EXTRAORDINARYSIZE 是厚度在6mm和10mm之间的陶瓷产品项目, 它使产品特别适合特殊的技术要求, 在轻盈和耐用方面能够适合“协议”领域的应用需要。



MARMINERO BELVEDERE 160x320 - 63"x126" LAP. RET.
 MARMISTATUARIO SPLENDEnte 160x320 - 63"x126" LAP. RET.
 MARMISTATUARIO SPLENDEnte SLAB A - B 160x320 - 63"x126" LAP. RET.



MARMISTATUARIO SPLENDEnte 160x320 - 63"x126" LAP.RET.
 MARMISTATUARIO SPLENDEnte SLAB A - B 160x320 - 63"x126" LAP.RET.



CONTEMPORANEI DISTRICTGRIGIO 160x320 - 63"x126" NAT. RET.
 CONTEMPORANEI DISTRICTBIANCO 160x320 - 63"x126" NAT. RET.
 BANCONE BAR/BAR COUNTER DISTRICT BIANCO



MARMIAZUL MACAUBA 160 x 320 - 63"x126" LAP. RET.
MARMILASA 160 x 320 - 63"x126" LAP. RET.



PIETRE&GRANITI COPACABANA PRINCESS 160x320 - 63"x126" LAP. RET.
 PIETRE&GRANITI COPACABANA EMPEROR 160x320 - 63"x126" LAP. RET.

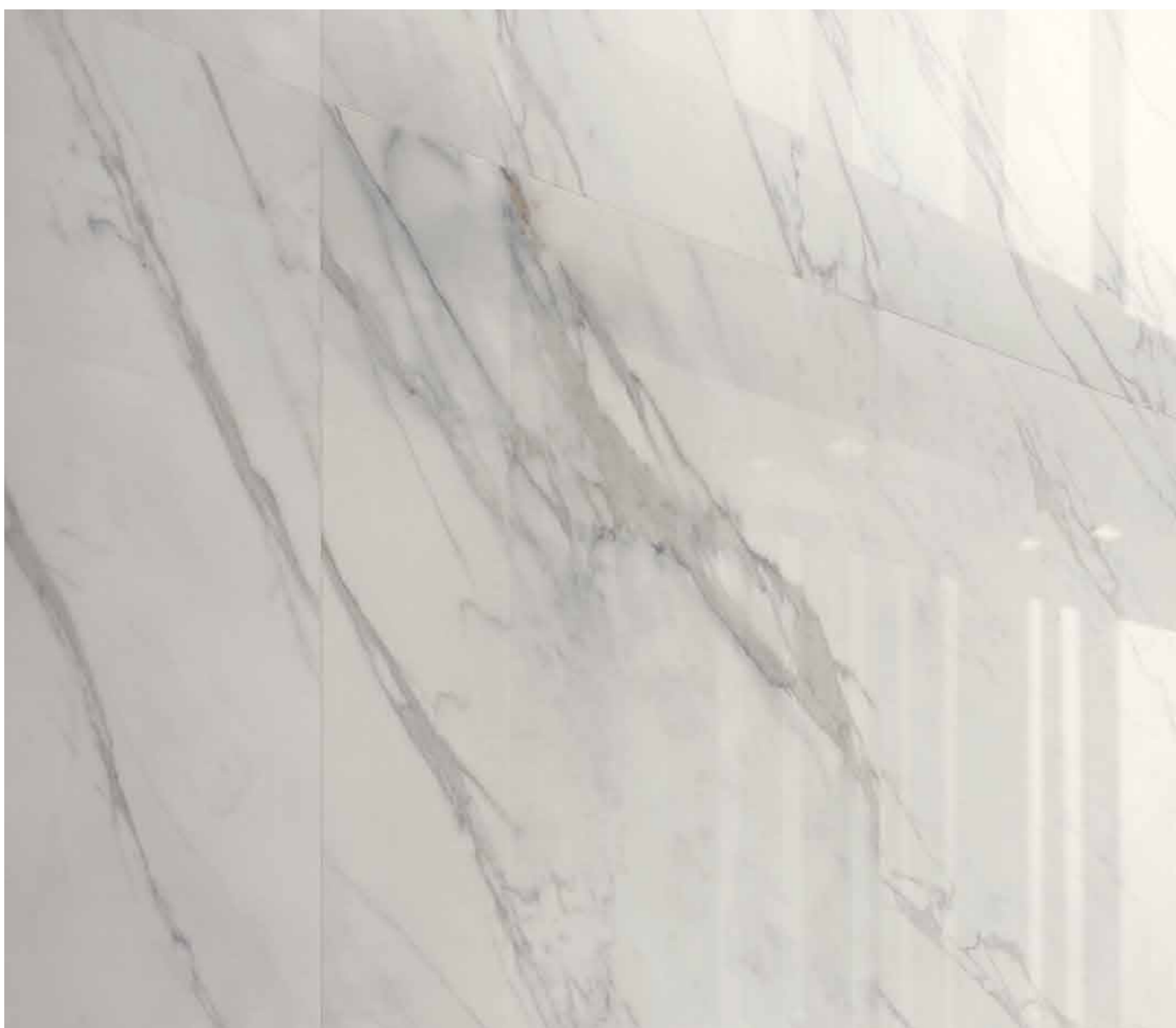

MARMICALACATTA 160x160 - 63x63" LAP. RET. . 160x320 - 63x126" LAP. RET.





ONICI AESTHETICA WILDE 160x320 - 63"x126" LAP. RET.

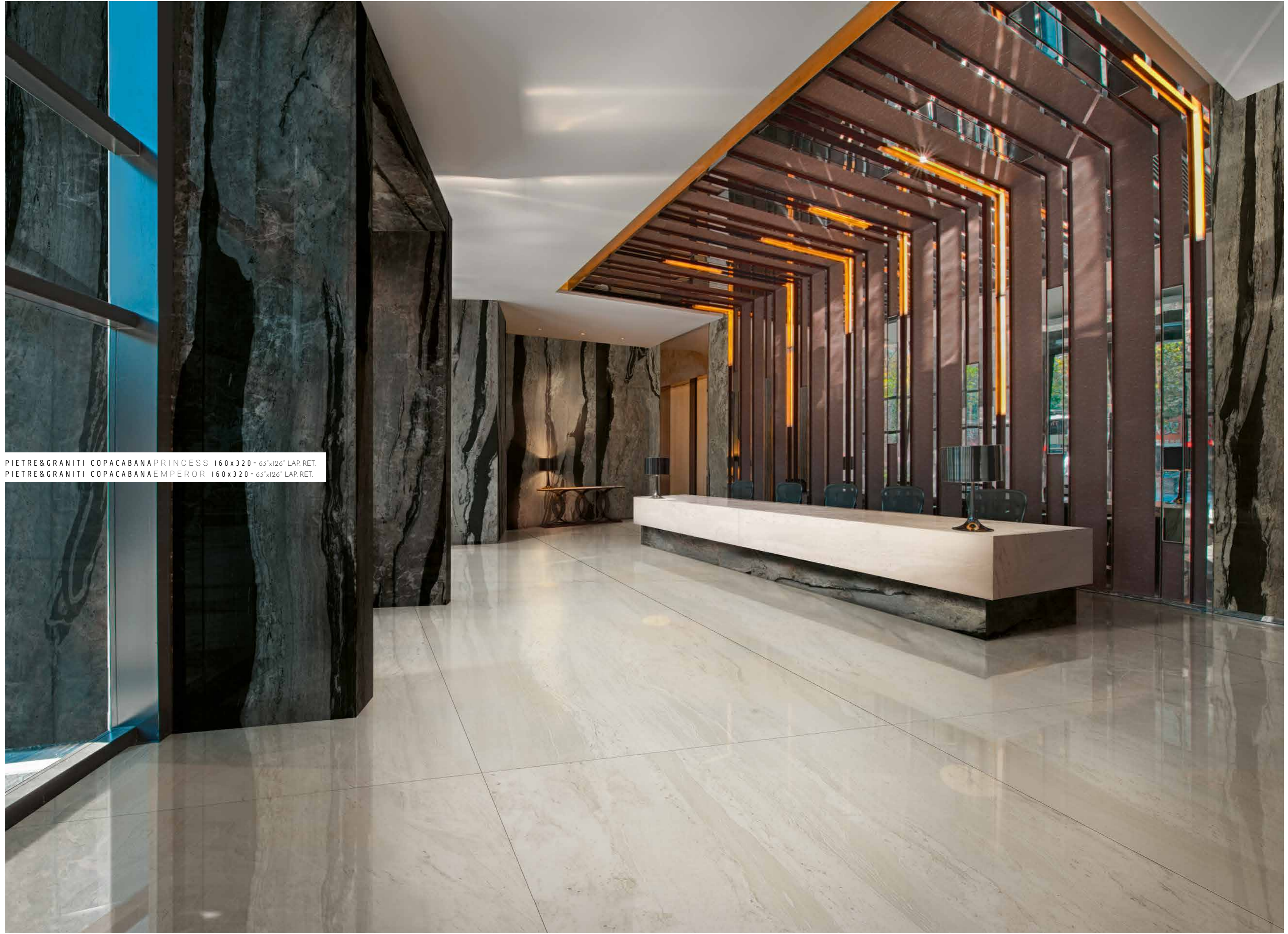

PIETRE&GRANITI COPACABANA PRINCESS 160x320 - 63"x126" LAP. RET.
PIETRE&GRANITI COPACABANA EMPEROR 160x320 - 63"x126" LAP. RET.



CONTEMPORANEI SKYLINEANTRACITE 120x240 - 48"x96" NAT.RET.
CONTEMPORANEI SKYLINEGHIACCIO 120x120 - 48"x48" NAT.RET.
WALLPAPER LUXPIANETI GRIGIO

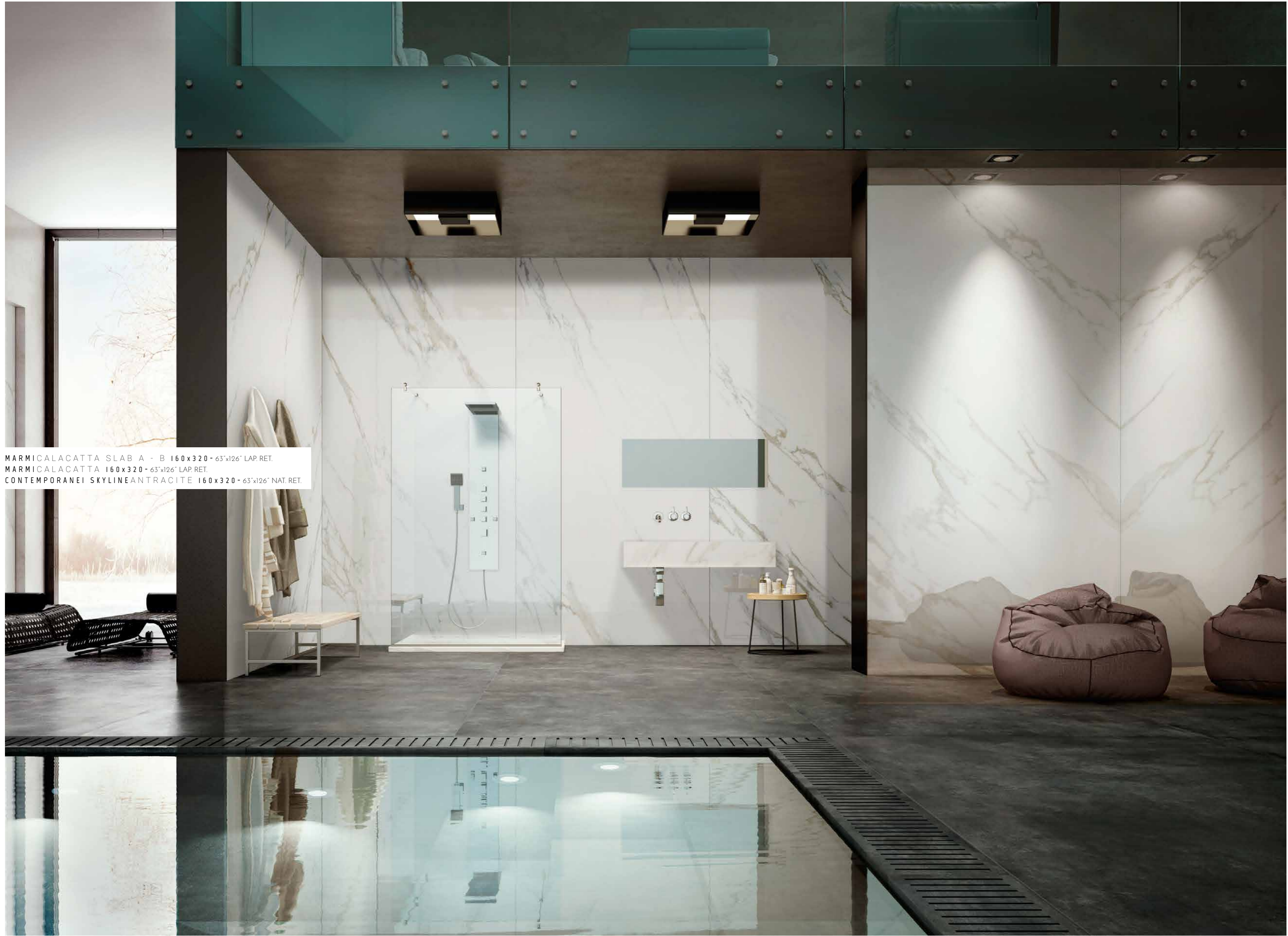

MARMICALACATTA SLAB A - B 160x320 - 63"x126" LAP. RET.
 MARMICALACATTA 160x320 - 63"x126" LAP. RET.
 CONTEMPORANEI SKYLINEANTRACITE 160x320 - 63"x126" NAT. RET.



CONTEMPORANEI SKYLINEFUMO 160x320 - 63"x126" NAT. RET.

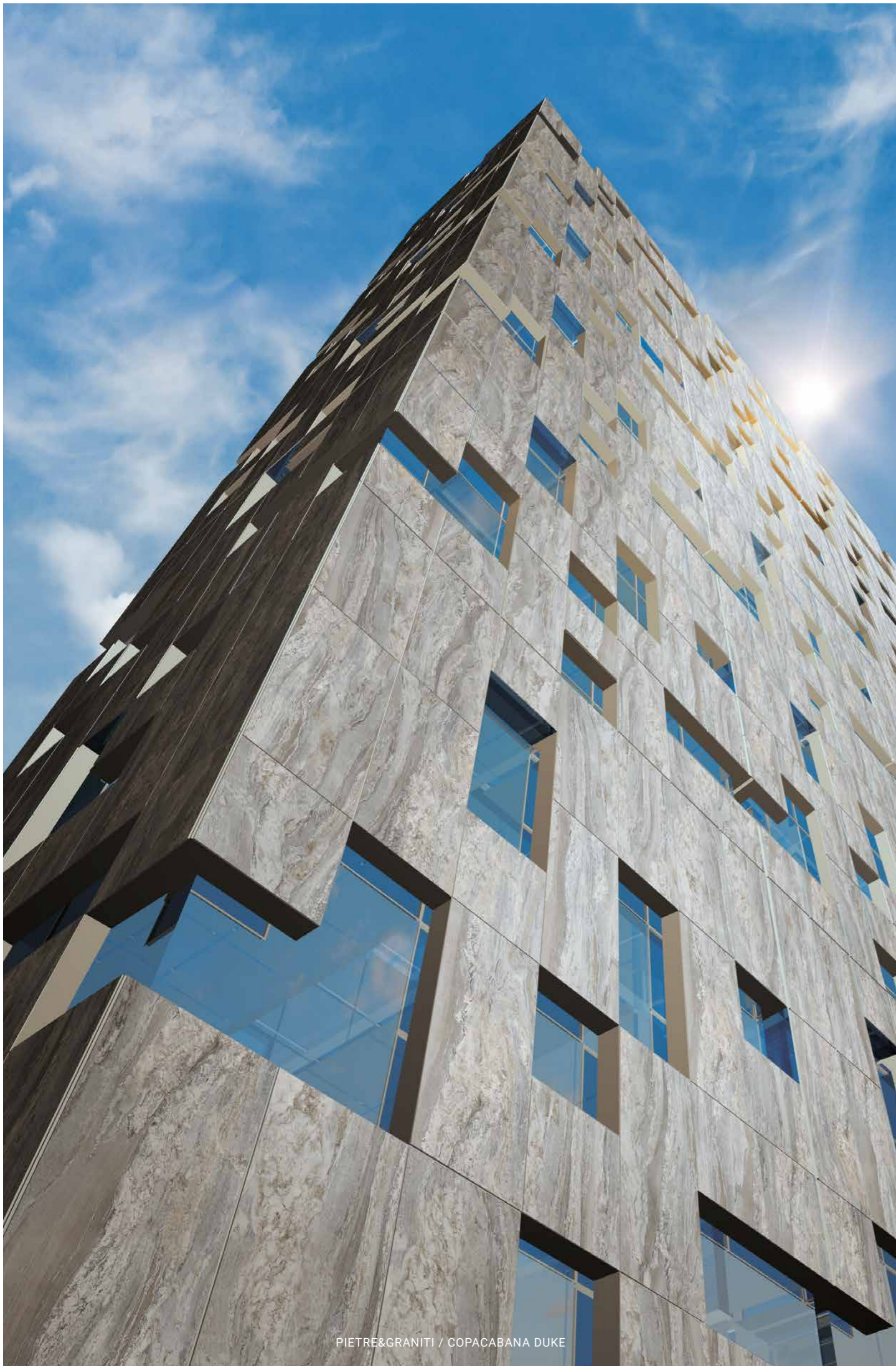

FACCIATE VENTILATE E INCOLLATE

Adhesive -Mounted Curtain Walls
 Façades ventilées et collées
 Hinterlüftete und verklebte Fassaden
 Fachadas ventiladas y encoladas
 Вентилируемые и наклеенные фасады
 胶合通风外墙

Le grandi lastre **EXTRAORDINARYSIZE** rappresentano l'evoluzione progettuale per la realizzazione di facciate ventilate e rivestite. Lo spessore sottile di 6 mm unito alle caratteristiche tecniche del gres porcellanato sono la risposta alle esigenze di leggerezza, resistenza, ingelività e inalterabilità nel tempo necessarie per rivestimenti outdoor.

The **EXTRAORDINARYSIZE** slabs are the latest offering for the construction of curtain walls and for cladding external walls. These lightweight extra-thin tiles (just 6 mm thick) with the technical features of porcelain stoneware are the ideal option for outdoor use, offering frost-resistance and stability over time.

Les grandes plaques **EXTRAORDINARYSIZE** représentent l'évolution conceptuelle pour la réalisation de façades ventilées et revêtues. L'épaisseur de 6 mm seulement associée aux caractéristiques techniques du grès cérame représente la réponse aux exigences de légèreté, de résistance, d'ingelivité et d'inaltérabilité dans le temps nécessaires pour les revêtements outdoor.

Die großen **EXTRAORDINARYSIZE**-Platten verkörpern die Entwurfentwicklung bei der Realisierung hinterlüfteter und verkleideter Fassaden. Die geringe Stärke von 6 mm in Verbindung mit den technischen Eigenschaften des Feinsteinzeugs sind die Antwort auf die Erfordernisse hinsichtlich geringem Gewicht, Widerstandsfähigkeit, Frostbeständigkeit und langer Haltbarkeit, die bei Bodenbelägen für Outdoor notwendig sind.

Las losas de grandes dimensiones **EXTRAORDINARYSIZE** representan la evolución del diseño para la realización de fachadas ventiladas y revestidas. Su reducido espesor de solo 6 mm y las características técnicas del gres porcelánico constituyen la respuesta a los requerimientos de ligereza, solidez, resistencia a las variaciones de temperatura y al hielo y duradera inalterabilidad, características todas necesarias para revestimientos de exteriores.

Плиты больших размеров **EXTRAORDINARYSIZE** представляют собой эволюцию проектирования вентилируемых и облицованных фасадов. Небольшая толщина всего лишь в 6 мм, а также высокие технические характеристики керамогранита удовлетворяют требования легкости, прочности, морозостойкости и неизменности с течением времени, которые должны соблюдаться при устройстве наружных облицовок.

巨大的**EXTRAORDINARYSIZE**型板是用于制造通风外墙及涂层的理想材料，这主要得益于其仅6mm厚的轻薄材质和瓷器本身抗寒性、耐热稳定性和耐大气、化学药剂腐蚀方面的技术特点。

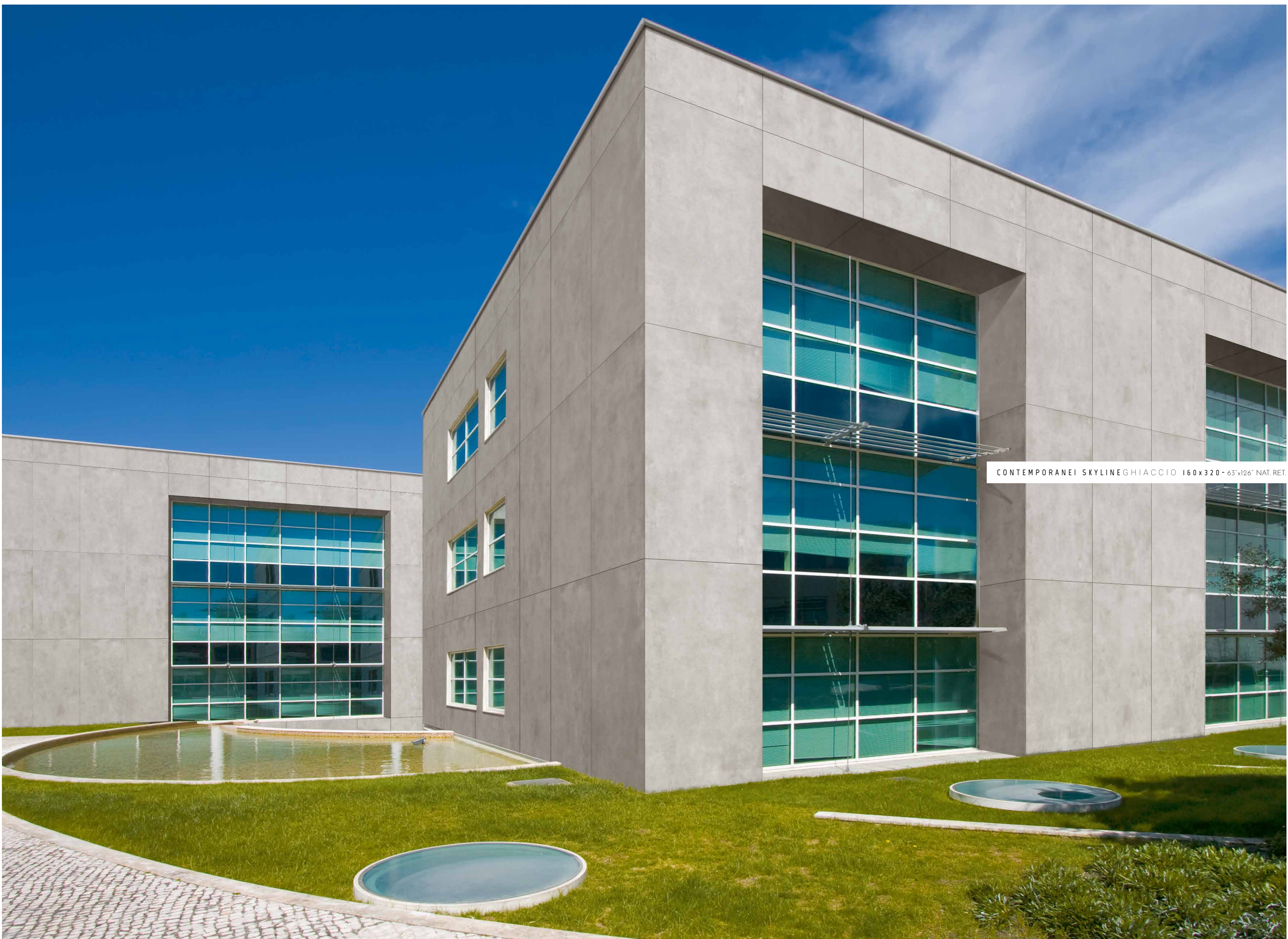

CONTEMPORANEI SKYLINEGHIACCIO 160x320 - 63"x126" NAT. RET.



I N D U S T R I A N A V A L E

Shipping industry
Industrie navale
Schiffbauindustrie
Industria naval
Кораблестроение
船舶工业

Grafiche di prestigio, spessori ridotti e alto valore tecnico del gres porcellanato: con queste caratteristiche le lastre EXTRAORDINARY SIZE possono essere utilizzate per impieghi navali, arredando yacht esclusivi o lussuose navi da crociera con innovazione estetica e tecnologica.

The technical characteristics of the porcelain stoneware, the beauty of the graphics and the lightness of the slabs make them ideal for furnishing exclusive yachts or luxury cruise ships.

Les caractéristiques techniques du grès cérame, la beauté des représentations graphiques et la légèreté des plaques, rendent ce matériau idéal pour meubler des yachts exclusifs, ou de luxueux navires de croisière.

Die technischen Eigenschaften des Feinsteinzeugs, die Schönheit der Grafiken und das geringe Gewicht der Platten machen sie zum idealen Partner bei Einrichtungen exklusiver und luxuriöser Yachten und Kreuzfahrtschiffe.

Las características técnicas del gres porcelánico, la belleza de los diseños gráficos y la ligereza de las losas las hacen ideales para decorar yates exclusivos y lujosos cruceros.

Технические характеристики керамогранита, красота графики и легкость плит делают последние идеальными для создания обстановки яхт и шикарных лайнеров.

由于板材具有独特的陶瓷技术特点、图案美观和重量轻等特点，时私家游艇和豪华游轮的理想装修材料。



ALCUNI ESEMPI DI BORDI / EXAMPLES OF EDGE PROFILES

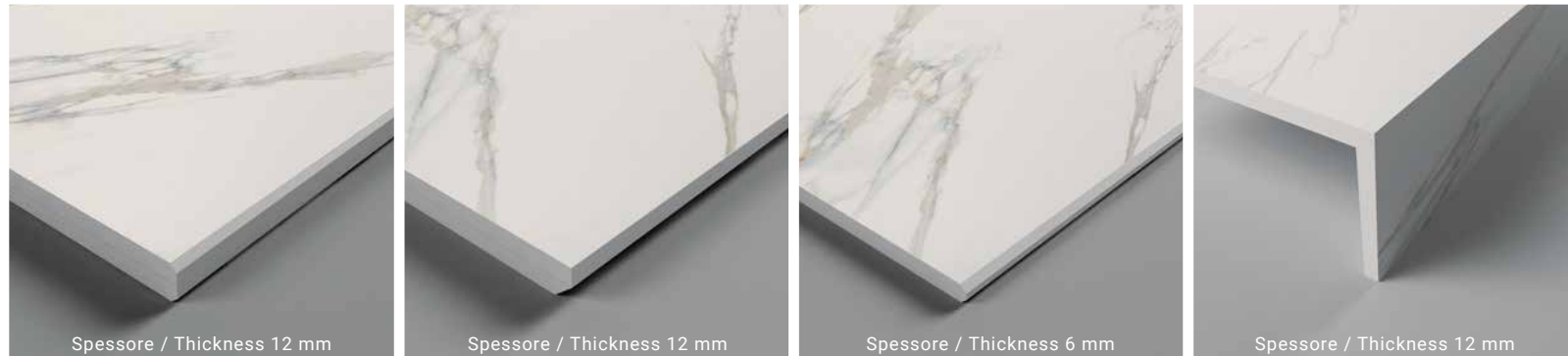

Spessore / Thickness 12 mm

Spessore / Thickness 12 mm

Spessore / Thickness 6 mm

Spessore / Thickness 12 mm

SUPERFICI / SURFACES



LAPPATO

NATURALE / NATURAL

TOP E RIVESTIMENTI COORDINATI

Coordinated top and covering
Top et revêtements coordonnés
Tops und koordinierte Verkleidungen
Encimeras y revestimientos coordinados
Комплекты столешниц и облицовок
顶面及辅助装饰

Con le lastre **EXTRAORDINARYSIZE** è possibile realizzare piani e top per cucine, mobili da bagno, arredi di soggiorni, coordinati e di qualsiasi forma e dimensione, garantendo il valore estetico e tecnologico di inassorbenza, idrorepellenza, resistenza agli agenti chimici, ai graffi e al calore del gres porcellanato.

With the extra slabs, you can make kitchen worktops and surfaces, bathroom and bedroom furniture, of any shape and with unrivalled technical characteristics of the porcelain stoneware, such as virtual zero absorbency, resistance to chemicals, scratches and heat.

Avec les plaques extra il est possible de réaliser des plans et des tops pour cuisines, meubles de salle de bains et séjours, de toute forme et avec les caractéristiques techniques inégalables du grès cérame comme la non absorption, la résistance aux agents chimiques, aux éraflures, à la chaleur.

Mit den extraordinary-Platten kann man Küchentops und Arbeitsplatten, Möbel für Bade- und Wohnzimmer in beliebigen Formen verwirklichen, die die unvergleichlichen technischen Eigenschaften des Feinsteinzeugs bieten, wie Absorptionsfestigkeit und Widerstandsfähigkeit gegen chemische Einflüsse, Kratzer und Wärme.

Con las losas extra es posible realizar superficies y encimeras para cocinas, muebles para el baño y salón, de cualquier forma y con las inigualables características técnicas del gres porcelánico como la inabsorbencia y la resistencia a los agentes químicos, a los arañazos y al calor.

Из плит extra можно реализовать полки и столешницы для кухонь, мебель для ванных и гостиных, любых форм, с несравненными техническими характеристиками, обусловленными свойствами керамогранита, такими как крайне низкая водопоглощаемость, устойчивость к действию химических агентов, царапанию, теплоустойчивость.

使用Extra板材，由于其具有其他产品无法比拟的陶瓷特性例如不吸收、耐化学物质腐蚀、耐刮花及耐颜色渗透等技术特点，可用于在任何形状的厨房、卫生间和起居家具顶面。

Dal dire al fare, dall'idea al prodotto: **EXTRAORDINARYSIZE** è total tailor-made. La flessibilità di utilizzo delle grandi lastre consente un'assoluta personalizzazione nella creazione di arredi, piani di lavoro, progetti dalle diverse destinazioni. **Forme, dimensioni, applicazioni: con Extraordinarysize ogni lavorazione è realizzata su misura per dare vita alla fantasia e alle richieste di ogni cliente, protagonista assoluto della propria creatività.**

From mind to matter, idea to product, EXTRAORDINARYSIZE is entirely tailor-made. The flexibility offered by these extra-large slabs allows users free reign to customise and create furniture, worktops, and designs for a host of uses. Shapes, sizes, applications: with Extraordinarysize all the materials are custom-processed to give form to the imagination and meet the needs of every single customer, making you the master of your own creativity.

De l'idée au produit : EXTRAORDINARYSIZE est entièrement réalisé sur mesure. La flexibilité d'utilisation des grandes dalles permet une personnalisation absolue lorsqu'on crée des décors, des plans de travail, des projets dans différents domaines. Formes, dimensions, applications : avec Extraordinarysize, chaque production est réalisée sur mesure pour laisser libre cours à l'imagination et aux demandes de chaque client, qui est le protagoniste absolu de sa créativité.

Das Design verbindet sich mit EXTRAORDINARYSIZE und nutzt ihre Vielseitigkeit, um Formen unterschiedlicher Inspiration zu entwickeln. Jede Idee wird maßgerecht durch Schneiden und Modellieren der großen Platten verwirklicht, um unterschiedliche und zeitgenössische Objekte zu schaffen, die die Räume durch vollkommene Originalität bereichern.

Del decir al hacer, de la idea al producto: EXTRAORDINARYSIZE es totalmente hecho a medida. La versatilidad de uso de las grandes losas garantiza una absoluta personalización en la creación ornamental, en los planes de trabajo y en proyectos con variados destinos. Formas, dimensiones, aplicaciones: con Extraordinarysize cada trabajo se realiza a medida para dar vida a la fantasía y a los requerimientos de cada cliente, protagonista absoluto de su propia creatividad.

От слов к делу, от идеи к изделию: EXTRAORDINARYSIZE - это работа полностью на заказ. Гибкость в использовании больших плит обеспечивает полную индивидуальность в оформлении интерьеров, изготовлении столешниц, реализации самых разнообразных проектов.

Формы, размеры, применения: благодаря Extraordinarysize любая обработка выполняется строго в размер, чтобы воплотить в жизнь фантазию и требования каждого клиента, являющегося основной фигурой своей креативности.

从说到做,从理念到产品: EXTRAORDINARYSIZE是全成衣制作。大片层运用的弹性有助于实现装饰制作、加工计划以及各种不同用途的绝对个性化。形状,大小,应用:凭借Extraordinarysize每一项加工都是定制的,为了满足每位客户的想象和要求,因为他们是自身创造力的绝对主角。

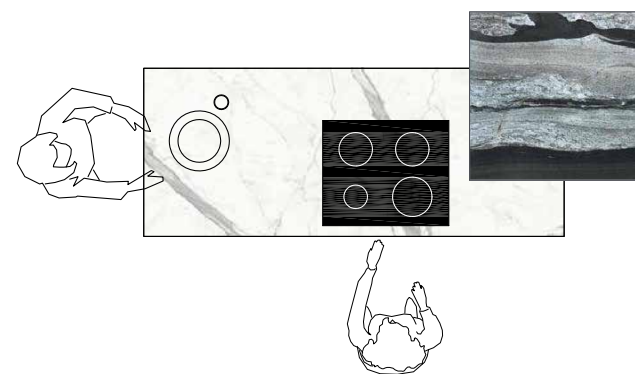
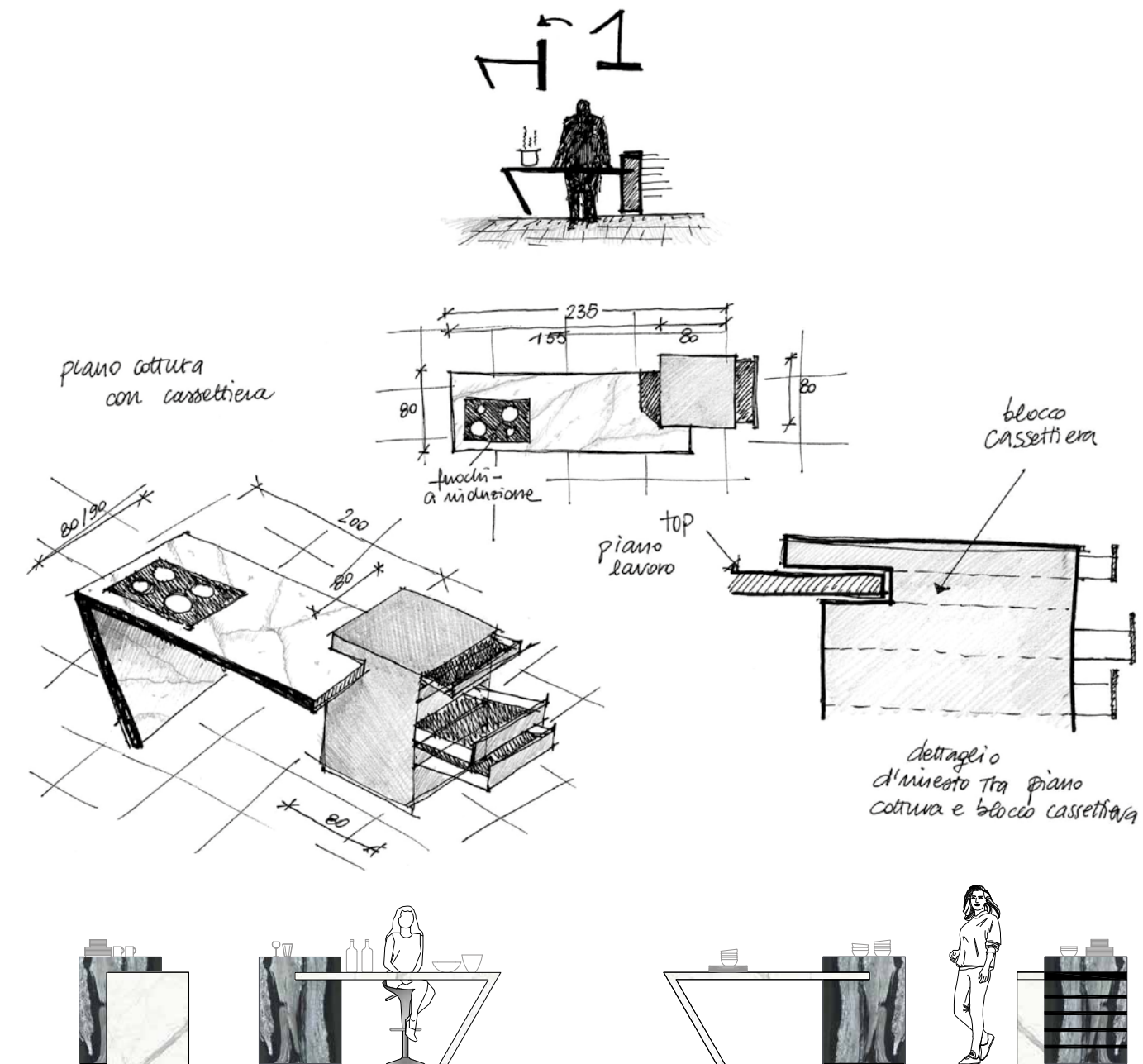



OGGETTI RIVESTITI CON / OBJECTS CLAD WITH MARMINI / BIANCO BERNINI LAP. RET.

A R R E D A M E N T O E D E S I G N

Furnishings
Ameublement
Einrichtung
Decoración
Оформление помещений
装修

La possibilità di personalizzare le lastre nelle forme, nelle grafiche e nelle dimensioni rende il progetto **EXTRAORDINARYSIZE** un vero materiale d'arredo, ideale per rivestire ogni tipo di struttura e ottenere composizioni di design, semplici da lavorare e pratiche da realizzare grazie al grande formato di 160x320 cm e allo spessore ridotto di 6 mm.

The ability of making custom cuts and any shape and size from a very large 160x320 cm slab, allows you to be able to clad structures and make furnishings customized by the most original and daring shapes.

La possibilité d'exécuter des coupes sur mesure et de toute forme et de toute dimension en partant d'une plaque de très grandes dimensions, 160x320 cm, permet de pouvoir revêtir des structures et d'obtenir des ameublements personnalisés aux formes originales et audacieuses.

Dank der Möglichkeit maßgeschneiderte Schnitte, Formen und Abmessungen von besonders großen Platten, 160x320 cm, anbieten zu können, kann man Strukturen verkleiden und originelle und außergewöhnliche Einrichtungsgegenstände kreieren.

La posibilidad de realizar cortes a medida y de cualquier forma y dimensión partiendo de una losa de grandísimas dimensiones de 160x320 cm, que permite revestir estructuras y obtener una decoración personalizada con las formas más originales y osadas.

Возможность нарезания плиток любых размеров и форм из плит очень больших размеров (160x320 см) позволяет облицовывать помещения и создавать обстановку по желанию, самых оригинальных и смелых форм.

使用大规格尺寸160x320 cm可以分割成任何尺寸和形状的板材，可用于铺设建筑表面，创造出个性化的原创和大胆图案装饰。



PAVIMENTO / FLOOR CONTEMPORANEI SKYLINE ANTRACITE 160x320 - 63"x126" NAT. RET.
 MOBILE RIVESTITO CON / FURNITURE CLAD WITH MARMI CALACATTA LAP. RET.



MARMÌ / CALACATTA

P O R T E E A N T E

Shutters and doors
Portes et battants
Türen und Schranktüren
Puertas y hojas
Двери и створки
门和窗板

Grazie allo spessore sottile, alla versatilità e alla robustezza del gres porcellanato, le lastre EXTRAORDINARYSIZE si prestano a rivestire porte e ante di ambienti pubblici e residenziali, garantendo continuità estetica con le superfici circostanti.

Thanks to the possibility of making cuts of any size and the lightness of the slab, extraordinarysize slabs can be used to cover shutters and doors, thus ensuring aesthetic continuity of the wall for a unique aesthetic effect.

Grâce à la possibilité d'effectuer des coupes de toutes dimensions et à leur légèreté, les plaques extraordinarysize peuvent être utilisées pour revêtir des portes et des battants, en garantissant ainsi la continuité esthétique de la paroi pour un effet unique.

Dank der Möglichkeit Schnitte in beliebigen großen Ausführen zu können und dank des geringen Gewichts der Platte, können die Extraordinarysize Platten zur Verkleidung von Türen und Schranktüren verwendet werden.

Gracias a la posibilidad de efectuar cortes de toda dimensión y a la ligereza de la losa, las losas extraordinarysize pueden utilizarse para revestir puertas y hojas garantizando de este modo la continuidad estética de la pared para producir un efecto estético único.

Благодаря возможности нарезания плиток любых размеров и легкости плиты extraordinarysize могут использоваться для облицовки дверей и створок, гарантируя, таким образом, зрительную непрерывность стены и уникальный эстетический эффект.

EXTRAORDINARYSIZE系列由于其重量轻和可分割成任何尺寸的特点，可以用于装修门面、窗板，保证与墙面具有相同的美观和独特的美观效果。

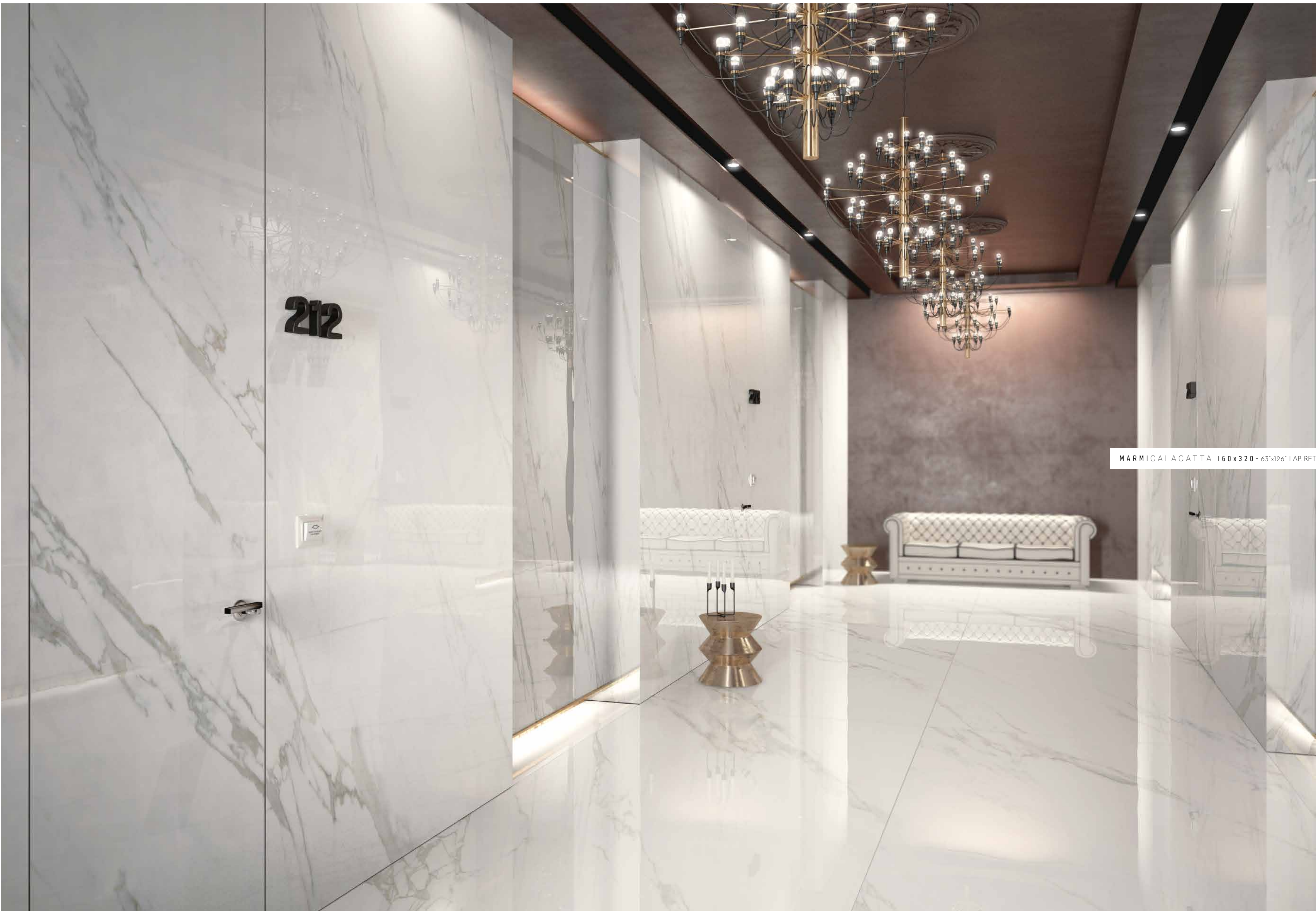

MARMICALACATTA 160 x 320 - 63"x126" LAP RET.

EXTRACOLORS

88 / MARMI

102 / ONICI

104 / PIETRE&GRANITI

106 / CONTEMPORANEI



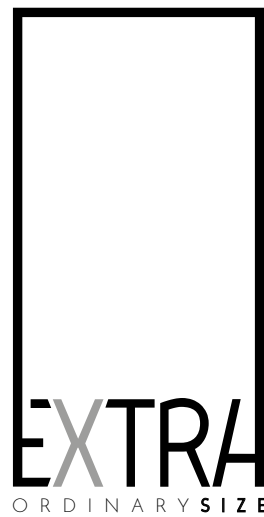

MARMI
STATUARIO SLAB A
 160x320. 63"x126"
 Lap. Ret. ○

MARMI
STATUARIO SLAB B
 160x320. 63"x126"
 Lap. Ret. ○

Esempio 1 / Example 1



Esempio 2 / Example 2

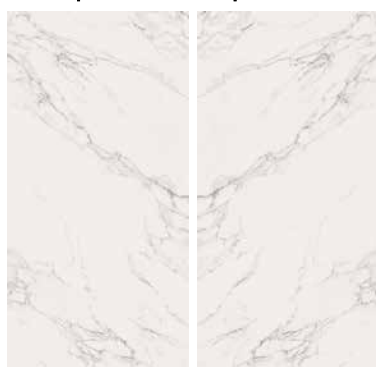

○ Lappato e rettificato.
 Lappato and rectified.
 Lappato et rectifié.
 Lappato und kalibriert.
 Lappato y rectificado.
 Лаппатированный ректифицированный.
 亚光和抛光。

○ Lappato e rettificato.
 Lappato and rectified.
 Lappato et rectifié.
 Lappato und kalibriert.
 Lappato y rectificado.
 Лаппатированный ректифицированный.
 亚光和抛光。

Esempio 3 / Example 3

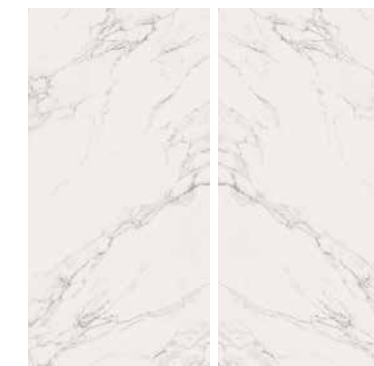

Esempio 4 / Example 4

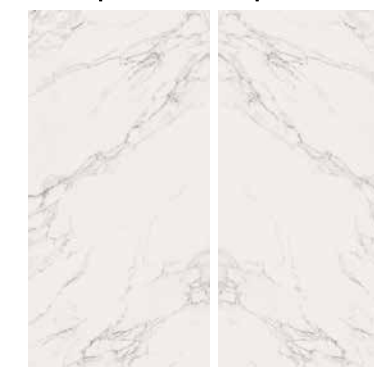

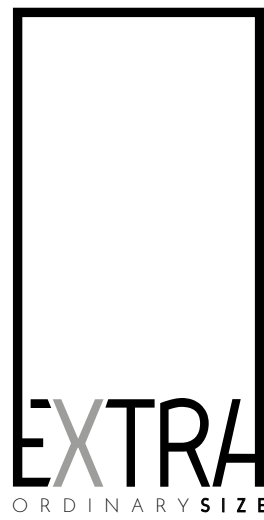

MARMI
STATUARIO SPLENDEnte **SLAB A**
160x320. 63"x126"
Lap. Ret. ○

Esempio 1 / Example 1

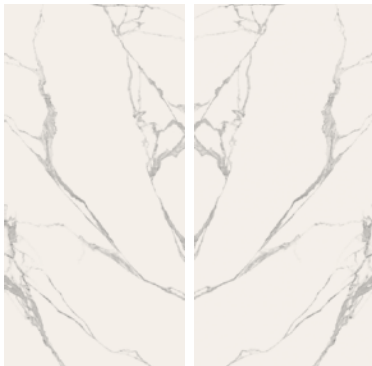

Esempio 2 / Example 2

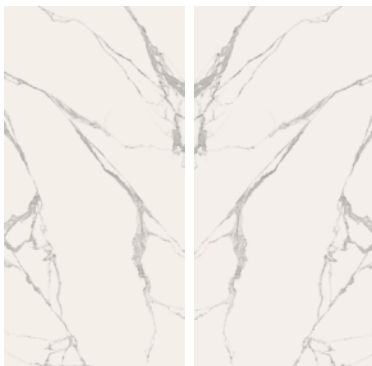

○ **Lappato e rettificato.**
Lappato and rectified.
Lappato et rectifié.
Lappato und kalibriert.
Lappato y rectificado.
Лаппатированный ректифицированный.
亚光和抛光。



MARMI
STATUARIO SPLENDEnte **SLAB B**
160x320. 63"x126"
Lap. Ret. ○

Esempio 3 / Example 3

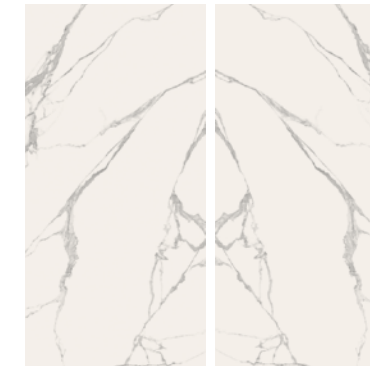

Esempio 4 / Example 4

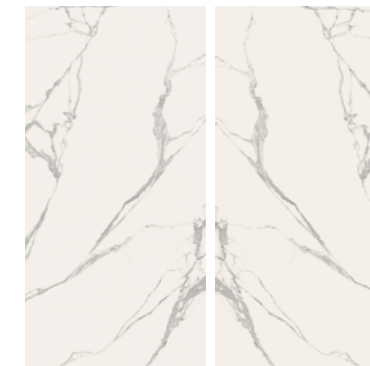

○ **Lappato e rettificato.**
Lappato and rectified.
Lappato et rectifié.
Lappato und kalibriert.
Lappato y rectificado.
Лаппатированный ректифицированный.
亚光和抛光。

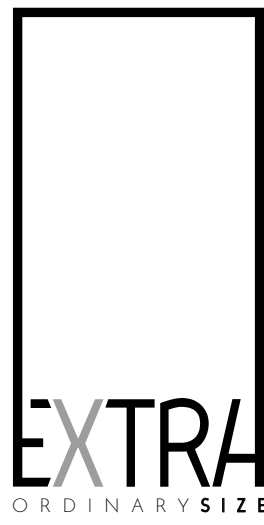

MARMI
CALACATTA SLAB A
160x320. 63"x126"
 Lap. Ret. ○

MARMI
CALACATTA SLAB B
160x320. 63"x126"
 Lap. Ret. ○



Esempio 1 / Example 1

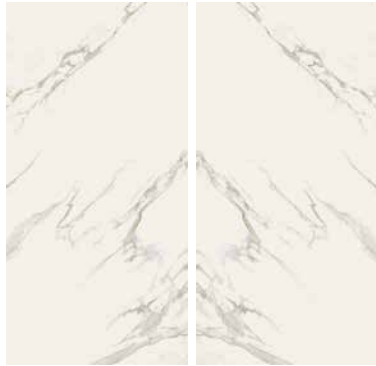

Esempio 2 / Example 2

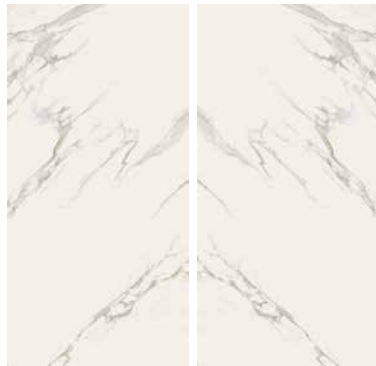

○ Lappato e rettificato.
 Lappato and rectified.
 Lappato et rectifié.
 Lappato und kalibriert.
 Lappato y rectificado.
 Лаппатированный ректифицированный.
 亚光和抛光。

○ Lappato e rettificato.
 Lappato and rectified.
 Lappato et rectifié.
 Lappato und kalibriert.
 Lappato y rectificado.
 Лаппатированный ректифицированный.
 亚光和抛光。

Esempio 3 / Example 3



Esempio 4 / Example 4

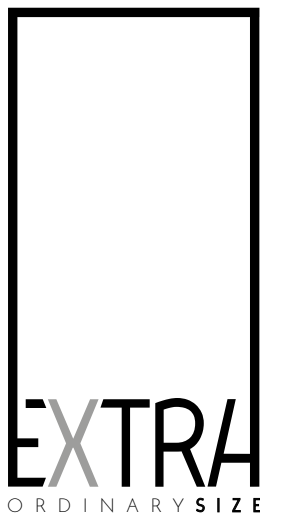

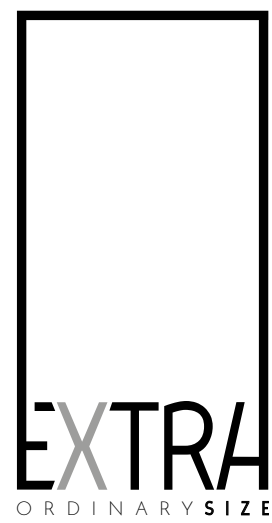

MARMI BARDIGLIO CENERE

SHADE
SPECTRUM

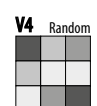
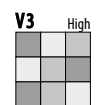
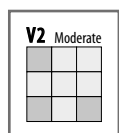
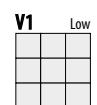

100% DESIGN
AND PRODUCTION
OF ITALY

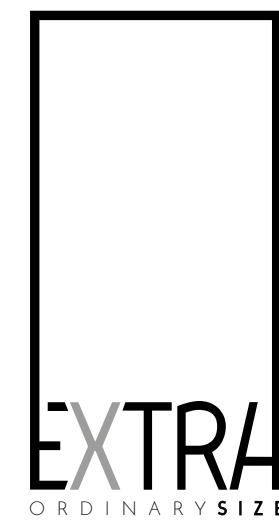

MARMI LASA

SHADE
SPECTRUM

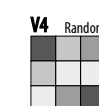
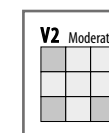
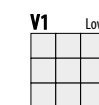

100% DESIGN
AND PRODUCTION
OF ITALY



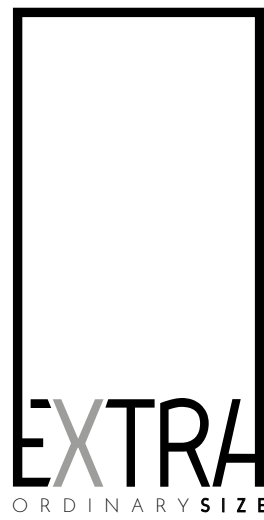

**MARMI
AZUL MACAUBA**

SHADE
SPECTRUM

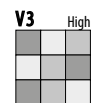
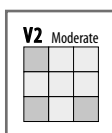
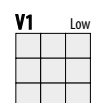

100% DESIGN
AND PRODUCTION
OF ITALY

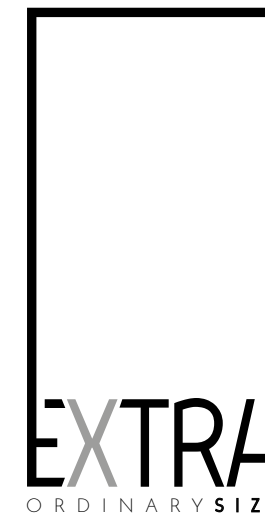

**MARMI
NERO BELVEDERE**

SHADE
SPECTRUM

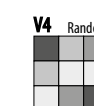
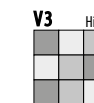
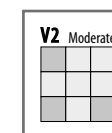
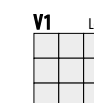

100% DESIGN
AND PRODUCTION
OF ITALY



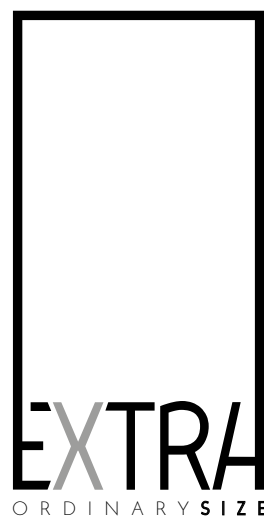

MARMI CREMA MARFIL

SHADE
SPECTRUM

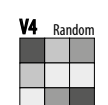
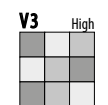
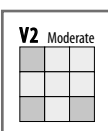
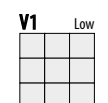

100% DESIGN
AND PRODUCTION
OF ITALY



MARMI

LASTRE IN GRES PORCELLANATO PRESSATE A SECCO

Dry-pressed porcelain stoneware slabs. Dalles en grès cérame pressées à sec. Trockengepresste Platten aus Feinsteinzeug. Planchas en gres porcelánico prensadas en seco. Керамогранитные плиты сухого прессования. 干压陶瓷砖

UNI EN 14411-ISO 13006 appendice C gruppo BIa - UGL

Spessore. Thickness. Epaisseur. Stärke. Espesor. Толщина. 厚度 **6mm - 10mm**

Grande varietà nelle grafiche per un pavimento o rivestimento sempre vario a effetto "naturale". - The collection is available in a wide variety of graphics for varied floor or wall solutions with a "natural" effect. Grande variété des graphiques pour un carrelage de sol ou un revêtement mural toujours différent et un effet "naturel". - Große Vielfalt der Graphiken für einen ständig unterschiedlichen Boden- oder Wandbelag mit "natürlichem" Effekt. - Gran variedad en las gráficas para un pavimento o revestimiento siempre diferente de efecto "natural". - Предлагается большое разнообразие рисунков для укладки всегда меняющегося пола или облицовки с натуральным эффектом. - 多样的图案让地板和涂层具有不同的“天然”色彩。



BARDIGLIO CENERE

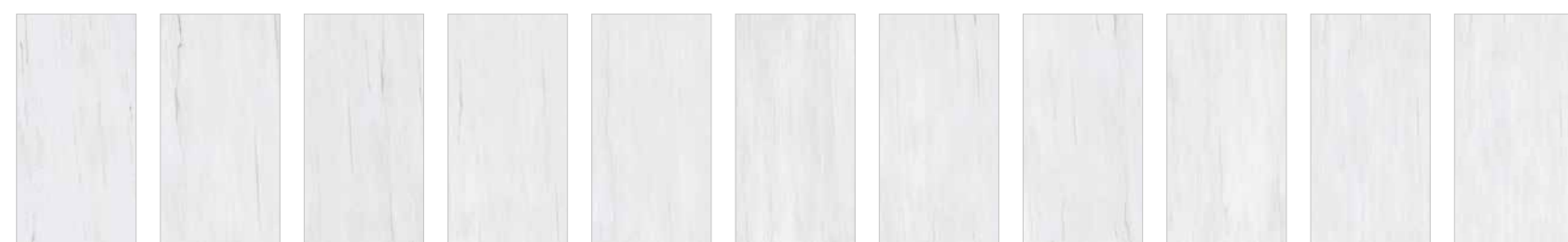

LASA

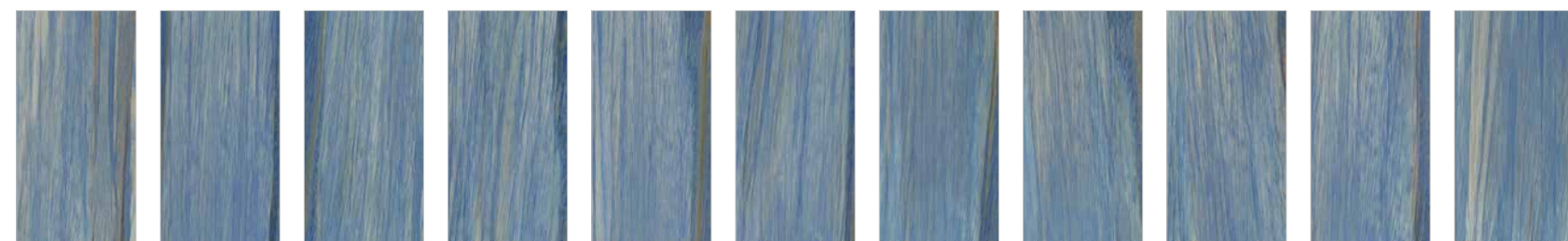

AZUL MACAUBA

| | | 160x320 63"x126" 6 mm | 120x240 48"x96" 6 mm | 160x160 63"x63" 6 mm | 120x120 48"x48" 6 mm | 80x160 31 1/2"x63" 6 mm | 80x240 31 1/2"x96" 6 mm | 80x80 31 1/2"x31 1/2" 6 mm | 60x120 24"x48" 10 mm | 60x60 24"x24" 10 mm |
|---------------------|-----------------------------|-----------------------------|----------------------------|----------------------------|----------------------------|-------------------------------|-------------------------------|----------------------------------|----------------------------|----------------------------|
| Bardiglio Cenerè | o Lappato Rettificato 6mm | 087005 | 087025 | 087045 | 087065 | 087085 | 087533 | 087105 | - | - |
| | □ Naturale Rettificato 6mm | 087006 | 087026 | 087046 | 087066 | 087086 | - | 087106 | - | - |
| | o Lappato Rettificato 10mm | - | - | - | - | - | - | - | 087125 | 087145 |
| | □ Naturale Rettificato 10mm | - | - | - | - | - | - | - | 087126 | 087146 |
| Lasa | o Lappato Rettificato 6mm | 087003 | 087023 | 087043 | 087063 | 087083 | - | 087103 | - | - |
| | □ Naturale Rettificato 6mm | 087004 | 087024 | 087044 | 087064 | 087084 | - | 087104 | - | - |
| | o Lappato Rettificato 10mm | - | - | - | - | - | - | - | 087123 | 087143 |
| | □ Naturale Rettificato 10mm | - | - | - | - | - | - | - | 087124 | 087144 |
| Azul Macauba | o Lappato Rettificato 6mm | 087001 | 087021 | 087041 | 087061 | 087081 | - | 087101 | - | - |
| | □ Naturale Rettificato 6mm | 087002 | 087022 | 087042 | 087062 | 087082 | - | 087102 | - | - |
| | o Lappato Rettificato 10mm | - | - | - | - | - | - | - | 087121 | 087141 |
| | □ Naturale Rettificato 10mm | - | - | - | - | - | - | - | 087122 *(min. 2.000 mq) | 087142 *(min. 2.000 mq) |

*Articolo disponibile per progetti (ordine minimo circa 2.000mq). Article available for large-scale projects (minimum order: approximately 2,000 m²). Article disponible pour les projets (commande minimale environ 2000 m²). Für Projekte verfügbarer Artikel (Mindestbestellung ca. 2.000 qm.). Artículo disponible para proyectos (pedido mínimo aproximadamente 2.000 m²). Этот артикул поставляется для крупных проектов (минимальный заказ – около 2000 кв.м.). 依项目而定的产品 (最小订单约2000平米)。

o Lappato e rettificato. Lappato and rectified. Lappato et rectifié. Lappato und kalibriert. Lappato y rectificado. Лаппатированный ректифицированный. 亚光和抛光。
□ Naturale e rettificato. Natural and rectified. Naturel et rectifié. Natur Oberfläche und kalibriert. Natural y rectificado. Натуральный ректифицированный. 天然和抛光。

LASTRE IN GRES PORCELLANATO PRESSATE A SECCO

Dry-pressed porcelain stoneware slabs. Dalles en grès cérame pressées à sec. Trockengepresste Platten aus Feinsteinzeug. Planchas en gres porcelánico prensadas en seco. Керамогранитные плиты сухого прессования. 干压陶瓷砖

UNI EN 14411-ISO 13006 appendice C gruppo BIa - UGL





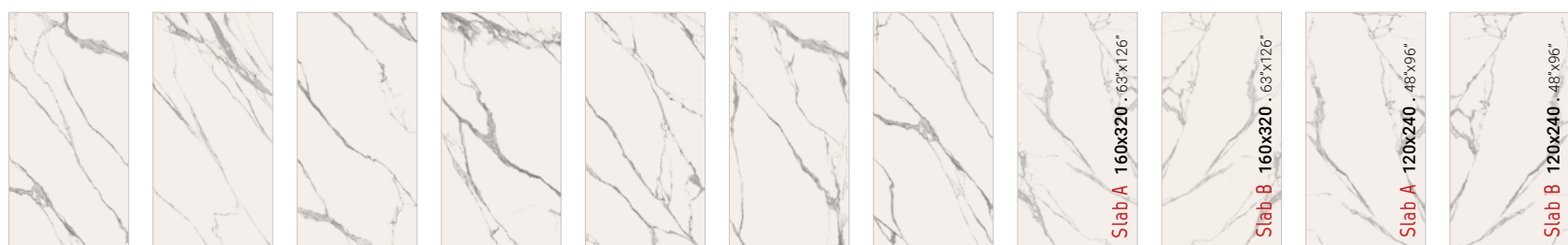

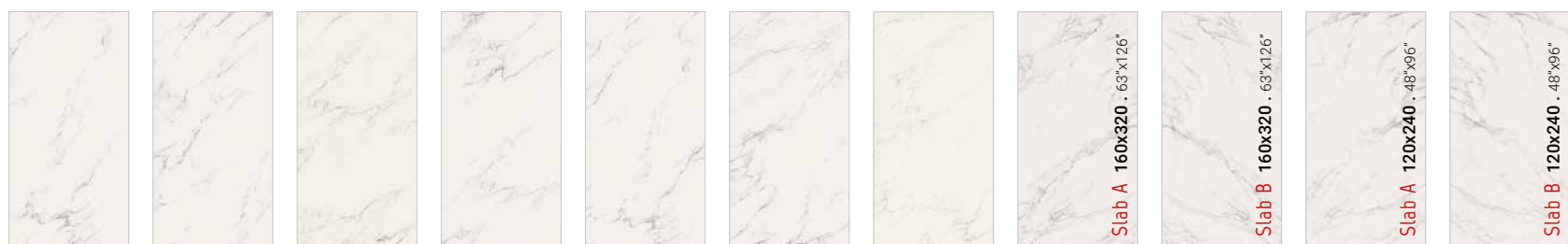

NERO BELVEDERE

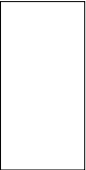

STATUARIO SPLENDEnte

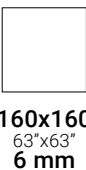

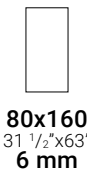
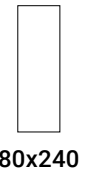
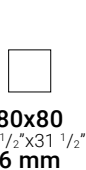
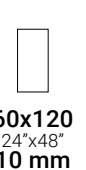
STATUARIO

| | |  |  |  |  |  |  |  |  |  |
|----------------------|-----------------------------|---|---|---|---|---|--|---|---|---|
| | | 160x320 63"x126" 6 mm | 120x240 48"x96" 6 mm | 160x160 63"x63" 6 mm | 120x120 48"x48" 6 mm | 80x160 31 1/2"x63" 6 mm | 80x240 31 1/2"x96" 6 mm | 80x80 31 1/2"x31 1/2" 6 mm | 60x120 24"x48" 10 mm | 60x60 24"x24" 10 mm |
| Nero Belvedere | o Lappato Rettificato 6mm | 087013 | 087033 | 087049 | 087069 | 087089 | - | 087109 | - | - |
| | o Lappato Rettificato 10mm | - | - | - | - | - | - | - | 087129 | 087149 |
| Statuario Splendente | o Lappato Rettificato 6mm | 087007 | 087027 | 087047 | 087067 | 087087 | 087532 | 087107 | - | - |
| | o Naturale Rettificato 6mm | 087008 | 087028 | 087048 | 087068 | 087088 | - | 087108 | - | - |
| | o Lappato Rettificato 10mm | - | - | - | - | - | - | - | 087127 | 087147 |
| | o Naturale Rettificato 10mm | - | - | - | - | - | - | - | 087128 | 087148 |
| Slab A | o Lappato Rettificato 6mm | 087009 | 087029 | - | - | - | - | - | - | - |
| | o Lappato Rettificato 10mm | 087011 | 087031 | - | - | - | - | - | - | - |
| Statuario | o Lappato Rettificato 6mm | 083003 | 083013 | 083023 | 083033 | 083043 | - | 083053 | - | - |
| | o Naturale Rettificato 6mm | 083004 | 083014 | 083024 | 083034 | 083044 | - | 083054 | - | - |
| | o Lappato Rettificato 10mm | - | - | - | - | - | - | - | 083063 | 083083 |
| | o Naturale Rettificato 10mm | - | - | - | - | - | - | - | 083064 | 083084 |
| Slab A | o Lappato Rettificato 6mm | 083091 | 083110 | - | - | - | - | - | - | - |
| | o Lappato Rettificato 10mm | 083092 | 083111 | - | - | - | - | - | - | - |

*Articolo disponibile per progetti (ordine minimo circa 2.000mq). Article available for large-scale projects (minimum order: approximately 2,000 m²). Article disponible pour les projets (commande minimale environ 2000 m²). Für Projekte verfügbarer Artikel (Mindestbestellung ca. 2.000 qm.). Artículo disponible para proyectos (pedido mínimo aproximadamente 2.000 m²). Этот артикул поставляется для крупных проектов (минимальный заказ – около 2000 кв.м.). 依项目而定的产品 (最小订单约2000平方米)。

Spessore. Thickness. Epaisseur. Stärke. Espesor. Толщина. 厚度 6mm - 10mm

Grande varietà nelle grafiche per un pavimento o rivestimento sempre vario a effetto "naturale" - The collection is available in a wide variety of graphics for varied floor or wall solutions with a "natural" effect. Grande variété des graphiques pour un carrelage de sol ou un revêtement mural toujours différent et un effet "naturel". - Große Vielfalt der Graphiken für einen ständig unterschiedlichen Boden- oder Wandbelag mit "natürlichem" Effekt. - Gran variedad en las gráficas para un pavimento o revestimiento siempre diferente de efecto "natural". - Предлагается большое разнообразие рисунков для укладки всегда меняющегося пола или облицовки с натуральным эффектом. - 多样的图案让地板和涂层具有不同的“天然”色彩。

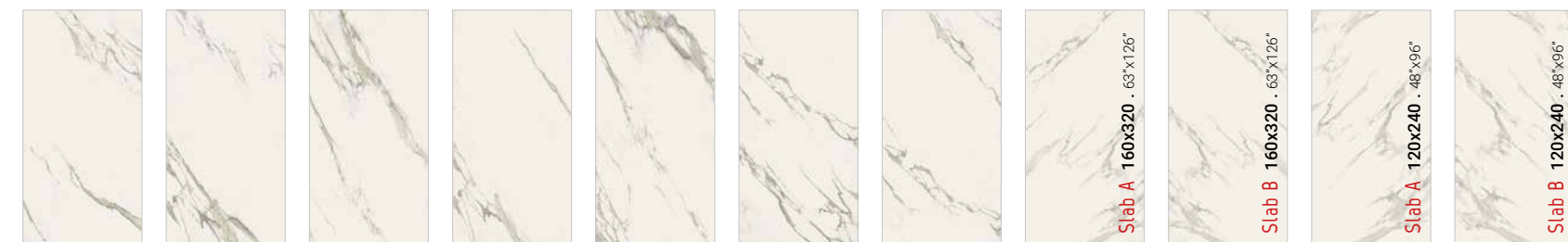



CALACATTA



CREMA MARFIL

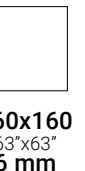
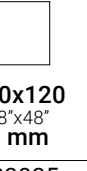
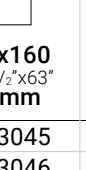
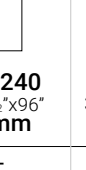
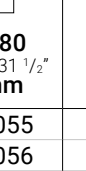
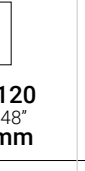
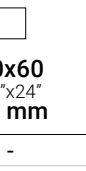

BIANCO BERNINI

| | |  |  |  |  |  |  |  |  |  |
|----------------|-----------------------------|---|---|---|---|---|---|---|---|---|
| | | 160x320 63"x126" 6 mm | 120x240 48"x96" 6 mm | 160x160 63"x63" 6 mm | 120x120 48"x48" 6 mm | 80x160 31 1/2"x63" 6 mm | 80x240 31 1/2"x96" 6 mm | 80x80 31 1/2"x31 1/2" 6 mm | 60x120 24"x48" 10 mm | 60x60 24"x24" 10 mm |
| Calacatta | o Lappato Rettificato 6mm | 083005 | 083015 | 083025 | 083035 | 083045 | - | 083055 | - | - |
| | o Naturale Rettificato 6mm | 083006 | 083016 | 083026 | 083036 | 083046 | - | 083056 | - | - |
| | o Lappato Rettificato 10mm | - | - | - | - | - | - | - | 083065 | 083085 |
| | o Naturale Rettificato 10mm | - | - | - | - | - | - | - | 083066 | 083086 |
| Slab A | o Lappato Rettificato 6mm | 083093 | 083112 | - | - | - | - | - | - | - |
| | o Lappato Rettificato 10mm | 083094 | 083113 | - | - | - | - | - | - | - |
| Crema Marfil | o Lappato Rettificato 6mm | 083009 | 083019 | 083029 | 083039 | 083049 | 083557 | 083059 | - | - |
| | o Naturale Rettificato 6mm | 083010 | 083020 | 083030 | 083040 | 083050 | - | 083060 | - | - |
| | o Lappato Rettificato 10mm | - | - | - | - | - | - | - | 083069 | 083087 *(min. 2.000 mq) |
| | o Naturale Rettificato 10mm | - | - | - | - | - | - | - | 083070 | 083088 *(min. 2.000 mq) |
| Bianco Bernini | o Lappato Rettificato 6mm | 083001 | 083011 | 083021 | 083031 | 083041 | - | 083051 | - | - |
| | o Naturale Rettificato 6mm | 083002 | 083012 | 083022 | 083032 | 083042 | - | 083052 | - | - |
| | o Lappato Rettificato 10mm | - | - | - | - | - | - | - | 083061 | 083081 *(min. 2.000 mq) |
| | o Naturale Rettificato 10mm | - | - | - | - | - | - | - | 083062 | 083082 *(min. 2.000 mq) |

o Lappato e rettificato. Lappato and rectified. Lappato et rectifié. Lappato und kalibriert. Lappato y rectificado. Лаппатированный ректифицированный. 亚光和抛光。
o Naturale e rettificato. Natural and rectified. Naturel et rectifié. Natur Oberfläche und kalibriert. Natural y rectificado. Натуральный ректифицированный. 天然和抛光。

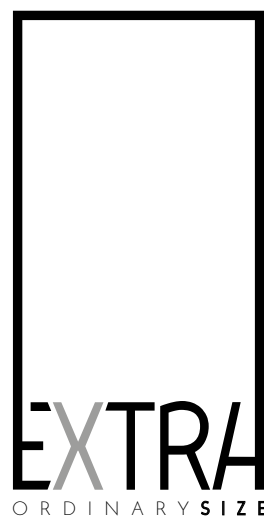

SHADE
SPECTRUM

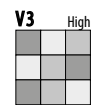
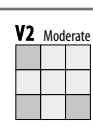
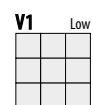

100% DESIGN
AND PRODUCTION
OF ITALY

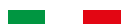

ONICI AESTHETICA WILDE

ONICI

AESTHETICA

LASTRE IN GRES PORCELLANATO PRESSATE A SECCO

Dry-pressed porcelain stoneware slabs. Dalles en grès cérame pressées à sec. Trockengepresste Platten aus Feinsteinzeug. Planchas en gres porcelánico prensadas en seco. Керамогранитные плиты сухого прессования. 干压陶瓷砖

UNI EN 14411-ISO 13006 appendice C gruppo BIa - UGL

Spessore. Thickness. Epaisseur. Stärke. Espesor. Толщина. 厚度 **6mm - 10mm**

Grande varietà nelle grafiche per un pavimento o rivestimento sempre vario a effetto "naturale". The collection is available in a wide variety of graphics for varied floor or wall solutions with a "natural" effect. Grande variété des graphiques pour un carrelage de sol ou un revêtement mural toujours différent et un effet "naturel". - Große Vielfalt der Graphiken für einen ständig unterschiedlichen Boden- oder Wandbelag mit "natürlichem" Effekt. - Gran variedad en las gráficas para un pavimento o revestimiento siempre diferente de efecto "natural". - Предлагается большое разнообразие рисунков для укладки всегда меняющегося пола или облицовки с натуральным эффектом. - 多样的图案让地板和墙面具有不同的“天然”色彩。



AESTHETICA HEGEL



AESTHETICA WILDE

| | | 160x320 63"x126" 6 mm | 120x240 48"x96" 6 mm | 160x160 63"x63" 6 mm | 120x120 48"x48" 6 mm | 80x160 31 1/2"x63" 6 mm | 80x80 31 1/2"x31 1/2" 6 mm | 60x120 24"x48" 10 mm |
|-------|------------------------------------|------------------------------------|-----------------------------------|-----------------------------------|-----------------------------------|--------------------------------------|---|-----------------------------------|
| Hegel | ○ Lappato Rettificato 6mm | 079001 | 079011 | 079021 | 079031 | 079041 | 079051 | - |
| | □ Naturale Rettificato 6mm | 079002 | 079012 | 079022 | 079032 | 079042 | 079052 | - |
| | ○ Lappato Rettificato 10mm | - | - | - | - | - | - | 079061 |
| | □ Naturale Rettificato 10mm | - | - | - | - | - | - | 079062 *(min. 2.000 mq) |
| Wilde | ○ Lappato Rettificato 6mm | 079005 | 079015 | 079025 | 079035 | 079045 | 079055 | - |
| | □ Naturale Rettificato 6mm | 079006 | 079016 | 079026 | 079036 | 079046 | 079056 | - |
| | ○ Lappato Rettificato 10mm | - | - | - | - | - | - | 079065 |
| | □ Naturale Rettificato 10mm | - | - | - | - | - | - | 079066 *(min. 2.000 mq) |

* Articolo disponibile per progetti (ordine minimo circa 2.000mq). Article available for large-scale projects (minimum order: approximately 2,000 m²). Article disponible pour les projets (commande minimale environ 2000 m²). Für Projekte verfügbarer Artikel (Mindestbestellung ca. 2.000 qm.). Artículo disponible para proyectos (pedido mínimo aproximadamente 2.000 m²). Этот артикул поставляется для крупных проектов (минимальный заказ – около 2000 кв.м.). 依项目而定的产品 (最小订单约2000平米)。

○ Lappato e rettificato. Lappato and rectified. Lappato et rectifié. Lappato und kalibriert. Lappato y rectificado. Лаппатированный ректифицированный. 亚光和抛光。
□ Naturale e rettificato. Natural and rectified. Naturel et rectifié. Natur Oberfläche und kalibriert. Natural y rectificado. Натуральный ректифицированный. 天然和抛光。

EXTRA
ORDINARY SIZE

SHADE
SPECTRUM

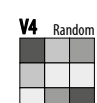
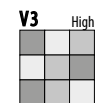
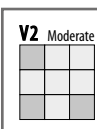
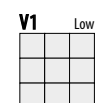

100% DESIGN
AND PRODUCTION
OF ITALY



PIETRE&GRANITI COPACABANA EMPEROR**

PIETRE&GRANITI

COPACABANA

LASTRE IN GRES PORCELLANATO PRESSATE A SECCO

Dry-pressed porcelain stoneware slabs. Dalles en grès cérame pressées à sec. Trockengepresste Platten aus Feinsteinzeug.

Planchas en gres porcelánico prensadas en seco. Керамогранитные плиты сухого прессования. 干压陶瓷砖

UNI EN 14411-ISO 13006 appendice C gruppo BIa - UGL

Spessore. Thickness. Epaisseur. Stärke. Espesor. Толщина. 厚度 **6mm - 10mm**

Grande varietà nelle grafiche per un pavimento o rivestimento sempre vario a effetto "naturale". The collection is available in a wide variety of graphics for varied floor or wall solutions with a "natural" effect. Grande variété des graphiques pour un carrelage de sol ou un revêtement mural toujours différent et un effet "naturel". - Große Vielfalt der Graphiken für einen ständig unterschiedlichen Boden- oder Wandbelag mit "natürlichem" Effekt. - Gran variedad en las gráficas para un pavimento o revestimiento siempre diferente de efecto "natural". - Предлагается большое разнообразие рисунков для укладки всегда меняющегося пола или облицовки с натуральным эффектом. - 多样的图案让地板和涂层具有不同的“天然”色彩。



COPACABANA PRINCESS



COPACABANA DUKE



COPACABANA EMPEROR**

| | | 160x320 63"x126" 6 mm | 120x240 48"x96" 6 mm | 120x120 48"x48" 6 mm | 80x160 31 1/2"x63" 6 mm | 60x120 24"x48" 10 mm |
|----------|-----------------------------|-----------------------------|----------------------------|----------------------------|-------------------------------|----------------------------|
| Princess | ○ Lappato Rettificato 6mm | 081001 | 081021 | 081051 | 081081 | - |
| | □ Naturale Rettificato 6mm | 081002 | 081022 | 081052 | 081082 | - |
| | ○ Lappato Rettificato 10mm | - | - | - | - | 081121 |
| | □ Naturale Rettificato 10mm | - | - | - | - | 081122 |
| Duke | ○ Lappato Rettificato 6mm | 081005 | 081025 | 081055 | 081085 | - |
| | □ Naturale Rettificato 6mm | 081006 | 081026 | 081056 | 081086 | - |
| | ○ Lappato Rettificato 10mm | - | - | - | - | 081125 |
| | □ Naturale Rettificato 10mm | - | - | - | - | 081126 |
| Emperor | ○ Lappato Rettificato 6mm | 081009 | 081029 | 081059 | 081089 | - |
| | □ Naturale Rettificato 6mm | 081010 | 081030 | 081060 | 081090 | - |
| | ○ Lappato Rettificato 10mm | - | - | - | - | 081129 |
| | □ Naturale Rettificato 10mm | - | - | - | - | 081130 |

○ Lappato e rettificato. Lappato and rectified. Lappato et rectifié. Lappato und kalibriert. Lappato y rectificado. Лаппатированный ректифицированный. 亚光和抛光。
□ Naturale e rettificato. Natural and rectified. Naturel et rectifié. Natur Oberfläche und kalibriert. Natural y rectificado. Натуральный ректифицированный. 天然和抛光。



** NOTE . Notes . Notes . Angaben . Notas . Примечания . 备注

Il grado di lappatura non uniforme del colore EMPEROR è dovuto alle speciali materie "affondanti" utilizzate per esaltare al massimo la profondità e l'intensità dei colori. The uneven lapping in the EMPEROR shade is due to special "sinking" materials, which are used to bring out the great depth and intensity of the colours. Le degré de rodage non uniforme de la couleur EMPEROR est dû aux matières spéciales "enfongantes" utilisées pour exalter au maximum la profondeur et l'intensité des couleurs. Die ungleichmäßig Lappung der EMPEROR-Farbe wird durch "einsinkende" Sondermaterialien geschaffen, die zur

größtmöglichen Hervorhebung der Tiefe und Intensität der Farben verwendet werden. El grado de lapeado no uniforme del color EMPEROR se debe a los materiales especiales "hundidores", utilizados para destacar al máximo la profundidad y la intensidad de los colores. Неравномерная степень притирки цвета EMPEROR вызвана специальными "утопящими" материалами, используемыми для максимального подчеркивания эффекта глубины и насыщенности цвета. 有特殊材料“沉坑”具有精研而颜色不均的颜色，常用于皇室装饰，因为可以衬托出最大颜色深度和强度。

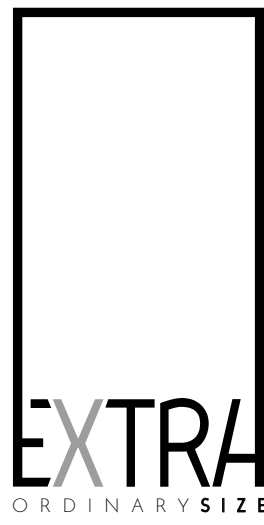

SHADE SPECTRUM

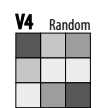
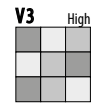
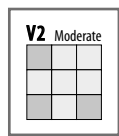
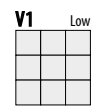

100% DESIGN
AND PRODUCTION
OF ITALY



CONTEMPORANEI
SKYLINE GHIACCIO

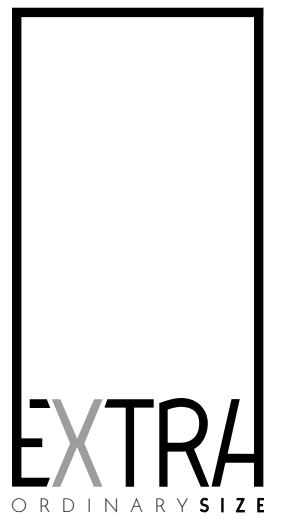
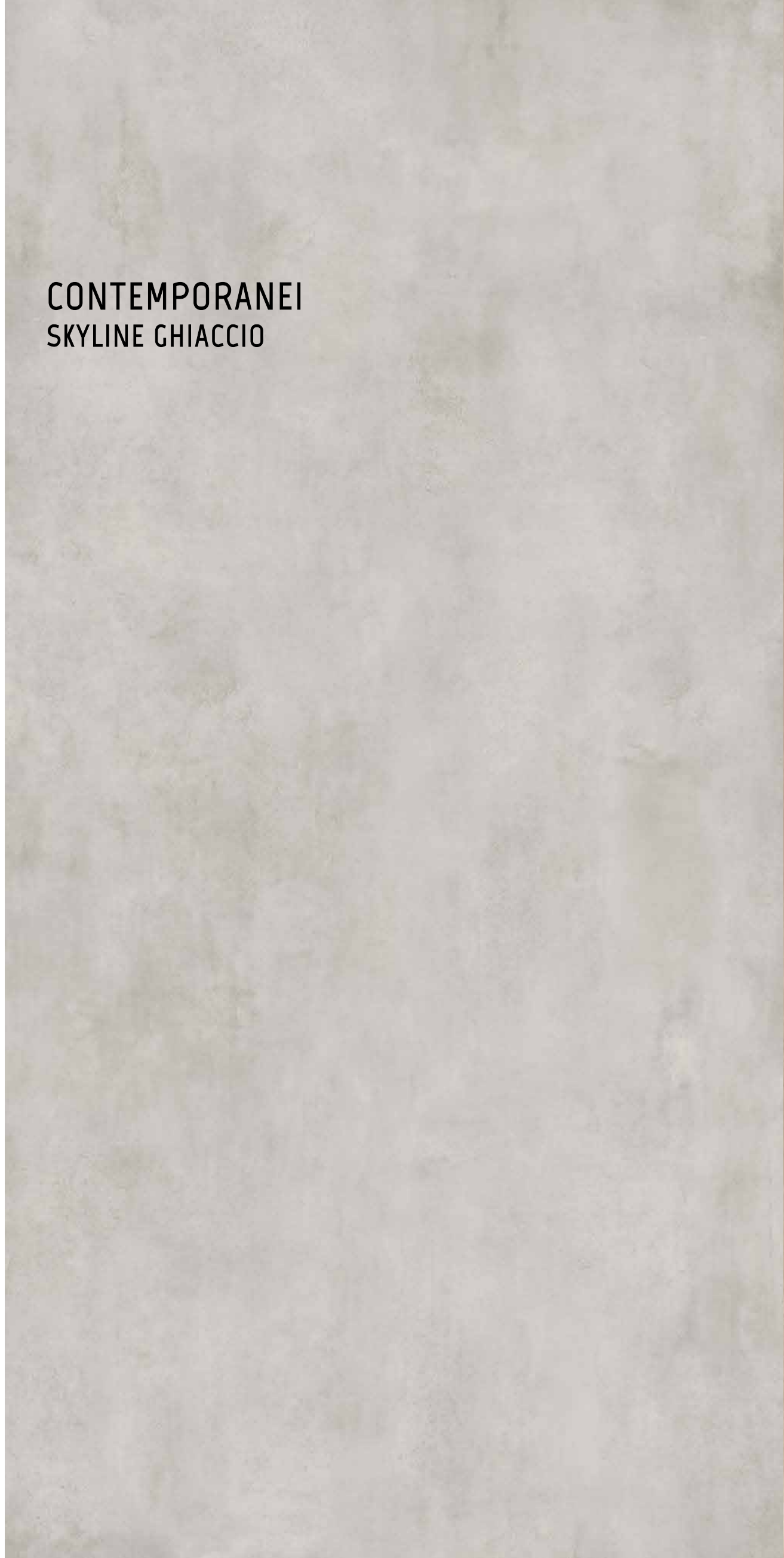

SHADE SPECTRUM

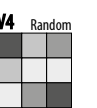
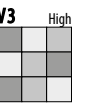
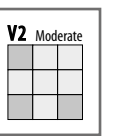
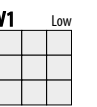

100% DESIGN
AND PRODUCTION
OF ITALY



CONTEMPORANEI
SKYLINE BEIGE



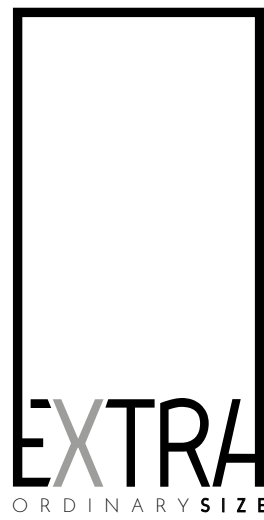

SHADE SPECTRUM

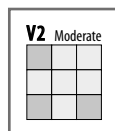
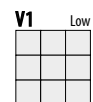

100% DESIGN AND PRODUCTION OF ITALY

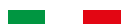

CONTEMPORANEI
SKYLINE FUMO

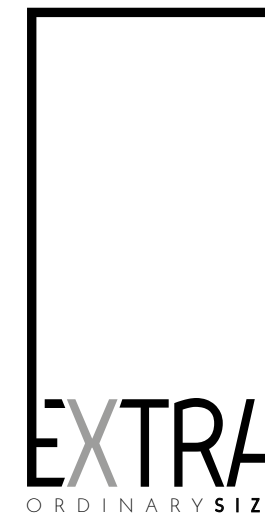

SHADE SPECTRUM

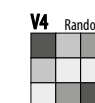
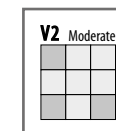
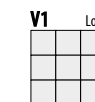

100% DESIGN AND PRODUCTION OF ITALY



CONTEMPORANEI
ABSOLUTE WHITE



CONTEMPORANEI
ABSOLUTE BLACK



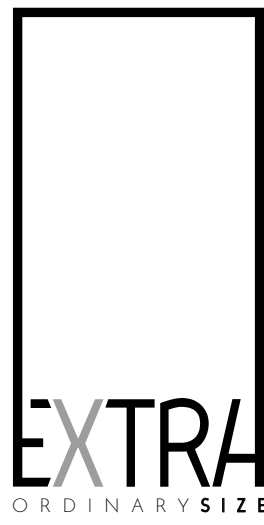

SHADE SPECTRUM

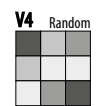
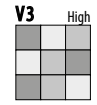
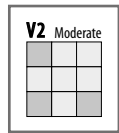
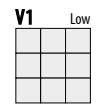

100% DESIGN
AND PRODUCTION
OF ITALY



CONTEMPORANEI
DISTRICT BIANCO

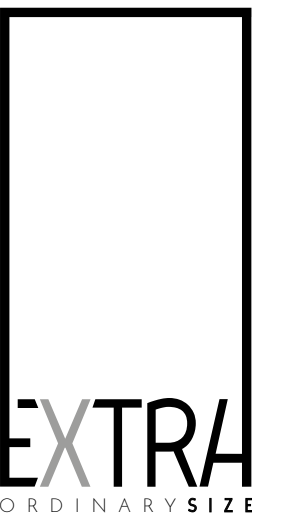

SHADE SPECTRUM

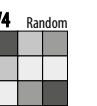
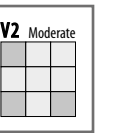

100% DESIGN
AND PRODUCTION
OF ITALY



CONTEMPORANEI
DISTRICT GRIGIO



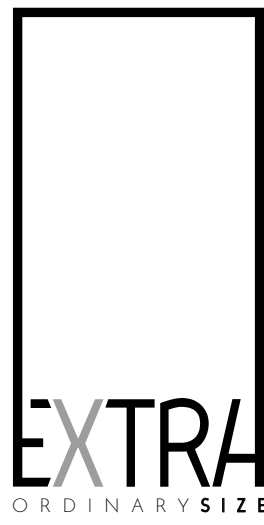

SHADE SPECTRUM

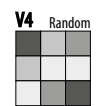
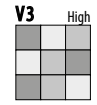
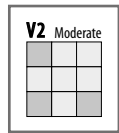
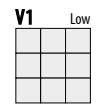

100% DESIGN
AND PRODUCTION
OF ITALY



CONTEMPORANEI
DISTRICT NERO

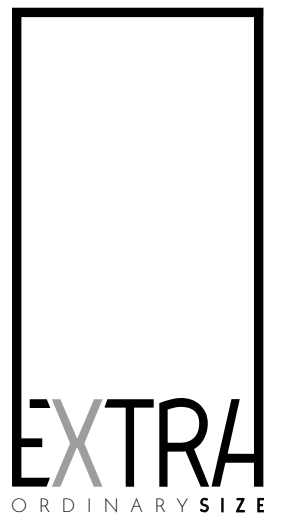

SHADE SPECTRUM

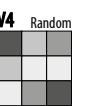
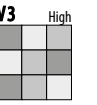
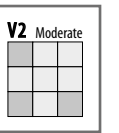
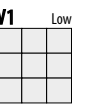

100% DESIGN
AND PRODUCTION
OF ITALY



CONTEMPORANEI
DISTRICT TORTORA



DISTRICT. ABSOLUTE. SKYLINE

LASTRE IN GRES PORCELLANATO PRESSATE A SECCO

Dry-pressed porcelain stoneware slabs. Dalles en grès cérame pressées à sec. Trockengepresste Platten aus Feinsteinzeug.

Planchas en gres porcelánico prensadas en seco. Керамогранитные плиты сухого прессования. 干压陶瓷砖

UNI EN 14411-ISO 13006 appendice C gruppo BIa - UGL



DISTRICT BIANCO



DISTRICT GRIGIO



DISTRICT TORTORA

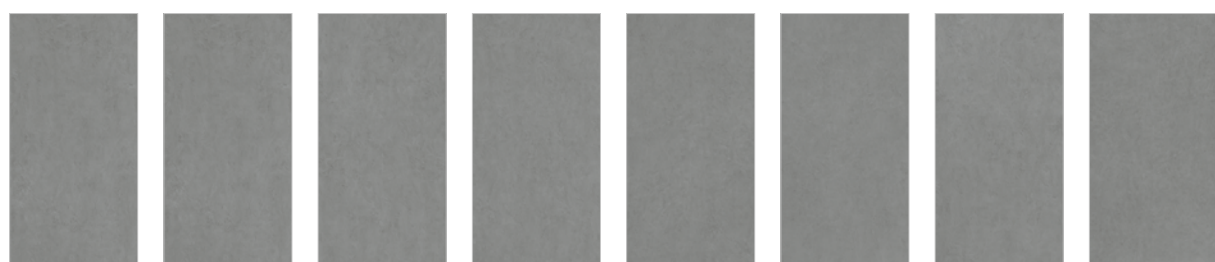



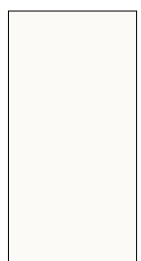

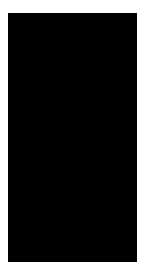

DISTRICT NERO

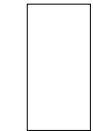

ABSOLUTE WHITE



ABSOLUTE BLACK

| | |  |  |  |  |  |  |  |  |
|------------------|--|---|---|---|---|--|---|---|---|
| | | 160x320 63"x126" 6 mm | 120x240 48"x96" 6 mm | 160x160 63"x63" 6 mm | 120x120 48"x48" 6 mm | 80x160 31 1/2"x63" 6 mm | 80x80 31 1/2"x31 1/2" 6 mm | 60x120 24"x48" 10 mm | 60x60 24"x24" 10 mm |
| District Bianco | <input type="checkbox"/> Naturale Rettificato 6mm | 096001 | 096021 | 096041 | 096061 | 096081 | 096101 | - | - |
| District Grigio | <input type="checkbox"/> Naturale Rettificato 6mm | 096002 | 096022 | 096042 | 096062 | 096082 | 096102 | - | - |
| District Tortora | <input type="checkbox"/> Naturale Rettificato 6mm | 096003 | 096023 | 096043 | 096063 | 096083 | 096103 | - | - |
| District Nero | <input type="checkbox"/> Naturale Rettificato 6mm | 096004 | 096024 | 096044 | 096064 | 096084 | 096104 | - | - |
| Absolute White | <input type="checkbox"/> Lappato Rettificato 6mm | 097001 | 097021 | 097031 | 097041 | 097051 | 097061 | - | - |
| | <input type="checkbox"/> Naturale Rettificato 6mm | 097002 | 097022 | 097032 | 097042 | 097052 | 097062 | - | - |
| | <input type="checkbox"/> Naturale Rettificato 10mm | - | - | - | - | - | - | 097081 | 097091 |
| Absolute Black | <input type="checkbox"/> Lappato Rettificato 6mm | 097004 | 097024 | 097034 | 097044 | 097055 | 097065 | - | - |
| | <input type="checkbox"/> Naturale Rettificato 6mm | 097005 | 097025 | 097035 | 097045 | 097056 | 097066 | - | - |
| | <input type="checkbox"/> Naturale Rettificato 10mm | - | - | - | - | - | - | 097085 | 097095 |

*Articolo disponibile per progetti (ordine minimo circa 2.000mq). Article available for large-scale projects (minimum order: approximately 2,000 m²). Article disponible pour les projets (commande minimale environ 2000 m²). Für Projekte verfügbarer Artikel (Mindestbestellung ca. 2.000 qm). Artículo disponible para proyectos (pedido mínimo aproximadamente 2.000 m²). Этот артикул поставляется для крупных проектов (минимальный заказ – около 2000 кв.м.). 依项目而定的产品 (最小订单约2000平方米)。

Spessore. Thickness. Epaisseur. Stärke. Espesor. Толщина. 厚度 6mm - 10mm

Grande varietà nelle grafiche per un pavimento o rivestimento sempre vario a effetto "naturale" - The collection is available in a wide variety of graphics for varied floor or wall solutions with a "natural" effect. Grande variété des graphiques pour un carrelage de sol ou un revêtement mural toujours différent et un effet "naturel". - Große Vielfalt der Graphiken für einen ständig unterschiedlichen Boden- oder Wandbelag mit "natürlichem" Effekt. - Gran variedad en las gráficas para un pavimento o revestimiento siempre diferente de efecto "natural". - Предлагается большое разнообразие рисунков для укладки всегда меняющегося пола или облицовки с натуральным эффектом. - 多样的图案让地板和涂层具有不同的“天然”色彩。



SKYLINE GHIACCIO











SKYLINE BEIGE

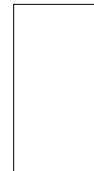

SKYLINE FUMO



SKYLINE ANTRACITE

| | |  |  |  |  |  |  |  |  |
|-----------|--|---|---|---|---|---|---|---|---|
| | | 160x320 63"x126" 6 mm | 120x240 48"x96" 6 mm | 160x160 63"x63" 6 mm | 120x120 48"x48" 6 mm | 80x160 31 1/2"x63" 6 mm | 80x80 31 1/2"x31 1/2" 6 mm | 60x120 24"x48" 10 mm | 60x60 24"x24" 10 mm |
| Ghiaccio | <input type="checkbox"/> Naturale Rettificato 6mm | 082001 | 082021 | 082041 | 082061 | 082081 | 082101 | - | - |
| | <input type="checkbox"/> Naturale Rettificato 10mm | - | - | - | - | - | - | 082121 | 082141 |
| | <input type="checkbox"/> Lappato Rettificato 10mm | - | - | - | - | - | - | 082122 | 082142 |
| Beige | <input type="checkbox"/> Naturale Rettificato 6mm | 082004 | 082024 | 082044 | 082064 | 082084 | 082104 | - | - |
| | <input type="checkbox"/> Naturale Rettificato 10mm | - | - | - | - | - | - | 082124 | 082144 |
| | <input type="checkbox"/> Lappato Rettificato 10mm | - | - | - | - | - | - | 082125 | 082145 |
| Fumo | <input type="checkbox"/> Naturale Rettificato 6mm | 082007 | 082027 | 082047 | 082067 | 082087 | 082107 | - | - |
| | <input type="checkbox"/> Naturale Rettificato 10mm | - | - | - | - | - | - | 082127 | 082147 |
| | <input type="checkbox"/> Lappato Rettificato 10mm | - | - | - | - | - | - | 082128 | 082148 |
| Antracite | <input type="checkbox"/> Naturale Rettificato 6mm | 082010 | 082030 | 082050 | 082070 | 082090 | 082110 | - | - |
| | <input type="checkbox"/> Naturale Rettificato 10mm | - | - | - | - | - | - | 082130 | 082150 |
| | <input type="checkbox"/> Lappato Rettificato 10mm | - | - | - | - | - | - | 082131 | 082151 |

Lappato e rettificato. Lappato and rectified. Lappato et rectifié. Lappato und kalibriert. Lappato y rectificado. Лаппатированный ректифицированный. 亚光和抛光。
 Naturale e rettificato. Natural and rectified. Naturel et rectifié. Natur Oberfläche und kalibriert. Natural y rectificado. Натуральный ректифицированный. 天然和抛光。

LASTRE IN GRES PORCELLANATO PRESSATE A SECCO

Dry-pressed porcelain stoneware slabs. Dalles en grès cérame pressées à sec. Trockengepresste Platten aus Feinsteinzeug.

Planchas en gres porcelánico prensadas en seco. Керамогранитные плиты сухого прессования. 干压陶瓷砖

UNI EN 14411-ISO 13006 appendice C gruppo Bla - UGL

MOSAICO

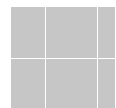
30x30cm. 12"x12"
thickness 6mm

* ETHNIC

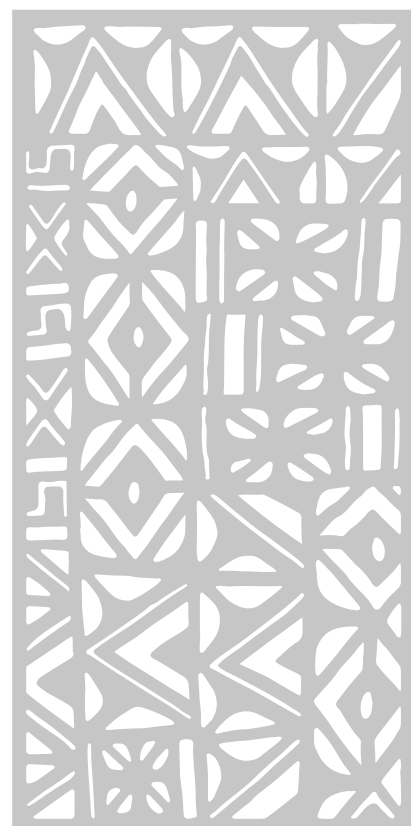
235,5x115cm. 93"x45 1/2"
thickness 13mm

* FLOWERS

235,5x115cm. 93"x45 1/2"
thickness 13mm

Decori disponibili su tutti i colori in gamma. Decors available for all the colors of this range. Décors disponibles dans toutes les couleurs de la gamme. Dekore in allen Farben der Kollektion verfügbar. Decorados disponibles en todos los colores. Декоры существуют во всех цветах коллекции. 装饰可以运用所有的颜色。

* I decori Ethnic e Flowers sono composti da 2 lastre incollate tra loro con inserimento di stuoia. The Ethnic and Flowers decorations feature two slabs stuck together with a rubber mesh in between. Les décors Ethnic et Flowers sont constitués par 2 plaques contrecollées avec l'insertion d'un filet antichoc. Die Dekorationen Ethnic und Flowers bestehen aus zwei miteinander verklebten Platten, zwischen die eine Matte eingelegt wird. Las decoraciones Ethnic y Flowers están compuestas por 2 placas encoladas entre sí, con aplicación de red delgada de refuerzo entre las placas. Декоры Ethnic и Flowers состоят из 2 склеенных друг с другом плит с проложенной между ними усиленной сеткой. Ethnic 与 Flowers 两种装饰由彼此交叉的2个板块组成, 其间有粘块连接。

○ Lappato e rettificato. Lappato and rectified. Lappato et rectifié. Lappato y kalibriert. Lappato y rectificado. Лаппатированный ректифицированный. 亚光和抛光。

□ Naturale e rettificato. Natural and rectified. Naturel et rectifié. Natur Oberfläche und kalibriert. Natural y rectificado. Натуральный ректифицированный. 天然和抛光。



PIETRE & GRANITI COPACABANA / Decoro ETHNIC PRINCESS 235,5x115 - 93"x45 1/2"

COSTA RETTA:
Straight nose:

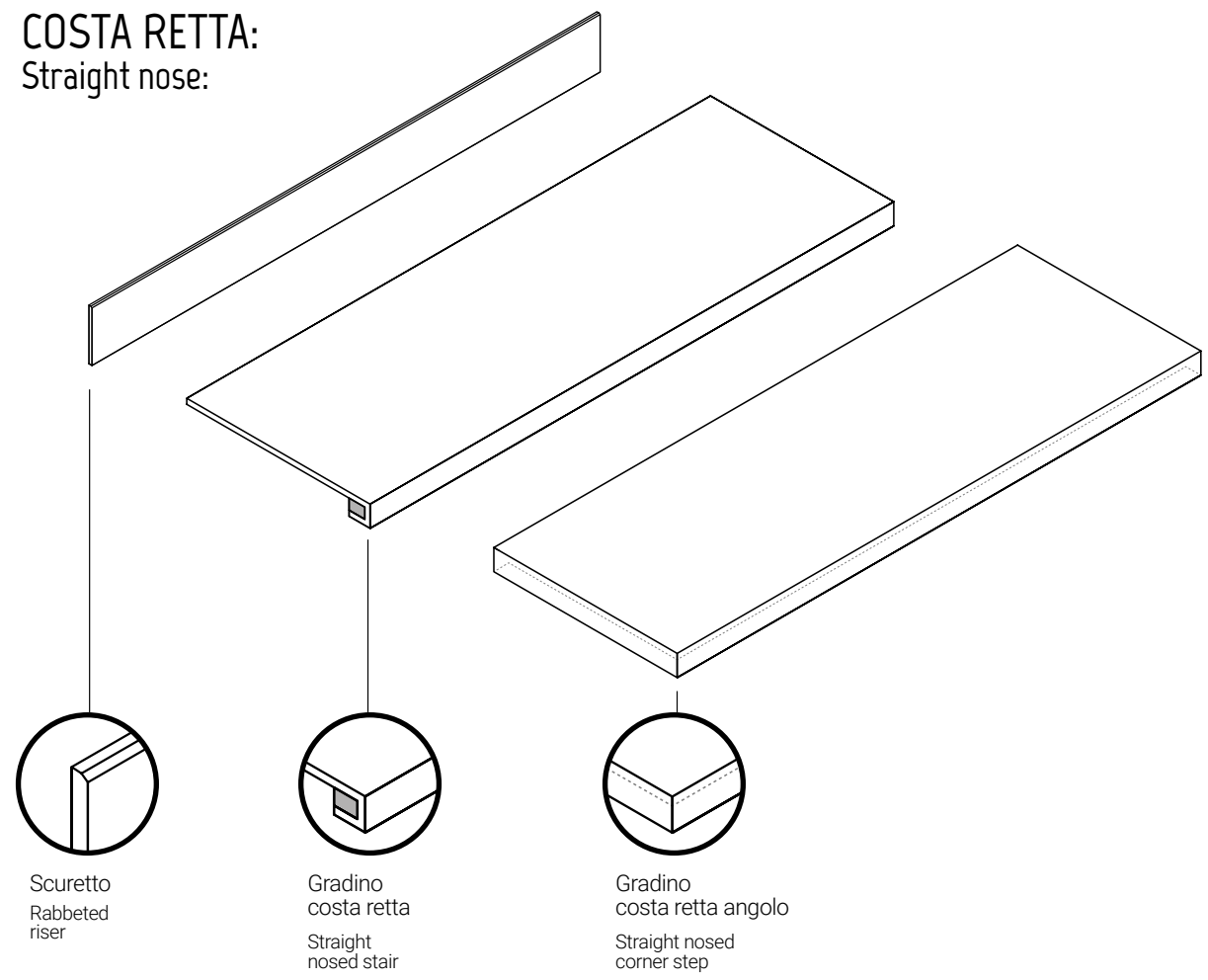

BORDO DRITTO:
Straight edge:

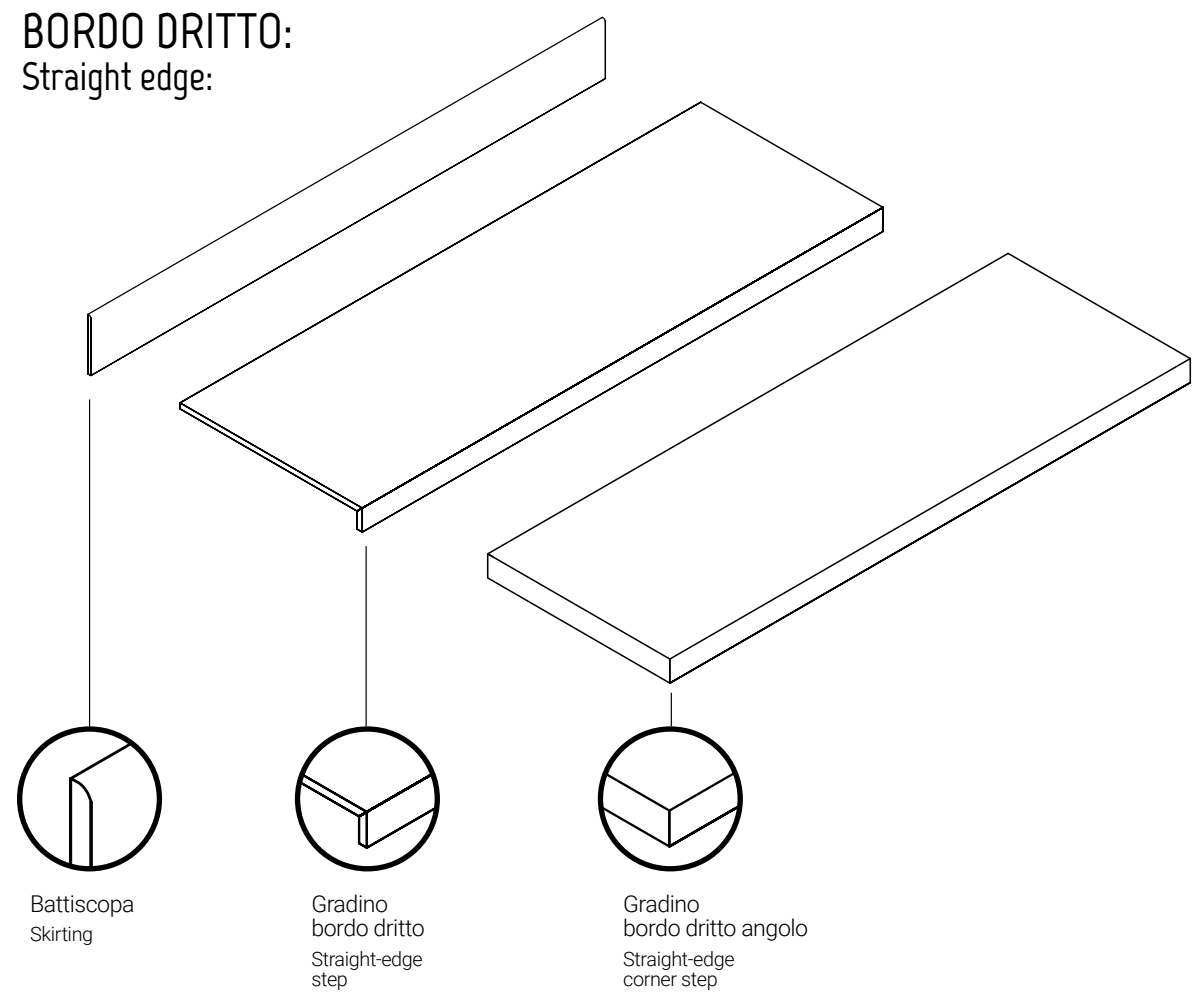





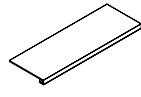
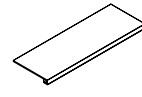
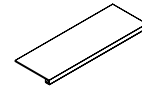
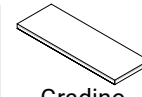
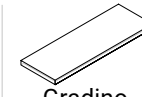
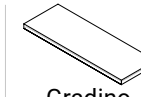
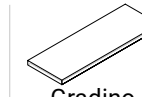
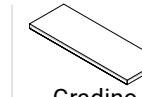

Per il gradino non si garantisce la stessa tonalità del fondo. We cannot guarantee that the shade of the stair tile will be the same as the background tile. Pour la marche, nous ne garantissons pas la même tonalité du fond. Für die Stufe wird nicht der gleiche Farbton des Untergrunds garantiert. Para el peldaño no se garantiza el mismo tono del fondo. Для ступени не гарантирована одинаковость тона с фоном. 对于台阶不保证底色一致

* A disposizione solo su richiesta. Tempi di consegna: 30gg. Available upon request only. Delivery terms: 30 days. Disponible seulement sur requête. Délais de livraison: 30 jours. Verfügbar auf Anfrage. Lieferzeit: 30 Tage. Disponible sólo bajo pedido. Plazo de entrega: 30 días. Изготавливается только по специальной заявке. Срок поставки: 30 дней. 仅依订购。交货时间: 30日。

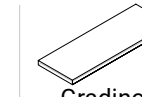
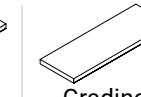
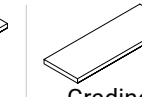
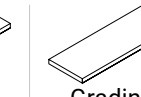
| | | Battiscopa 120x6,5 48"x2 1/2" | Battiscopa 80x8 31 1/2"x3" | Scuretto 160x20 63"x8" | Scuretto 120x20 48"x8" | Scuretto 80x20 31 1/2"x8" | |
|------------|----------------------|--|--|------------------------------|------------------------------|---------------------------------|---|
| MARMINI | Bianco Bernini | ○ Lap. Ret. 10 mm ✓ □ Nat. Ret. 10 mm - ○ Lap. Ret. 6 mm - □ Nat. Ret. 6 mm - | - | - | ✓ | - | |
| | Calacatta | ○ Lap. Ret. 10 mm ✓ □ Nat. Ret. 10 mm - ○ Lap. Ret. 6 mm - □ Nat. Ret. 6 mm - | - | ✓ | ✓ | ✓ | |
| | Crema Marfil | ○ Lap. Ret. 10 mm ✓ □ Nat. Ret. 10 mm - ○ Lap. Ret. 6 mm - □ Nat. Ret. 6 mm - | - | ✓ | ✓ | ✓ | |
| | Statuario | ○ Lap. Ret. 10 mm ✓ □ Nat. Ret. 10 mm - ○ Lap. Ret. 6 mm - □ Nat. Ret. 6 mm - | - | ✓ | ✓ | ✓ | |
| | Statuario Splendente | ○ Lap. Ret. 10 mm ✓ □ Nat. Ret. 10 mm - ○ Lap. Ret. 6 mm - □ Nat. Ret. 6 mm - | - | ✓ | ✓ | ✓ | |
| | Bardiglio | ○ Lap. Ret. 10 mm ✓ □ Nat. Ret. 10 mm - ○ Lap. Ret. 6 mm - □ Nat. Ret. 6 mm - | - | ✓ | ✓ | ✓ | |
| | Lasa | ○ Lap. Ret. 10 mm ✓ □ Nat. Ret. 10 mm - ○ Lap. Ret. 6 mm - □ Nat. Ret. 6 mm - | - | ✓ | ✓ | ✓ | |
| | Azul Macauba | ○ Lap. Ret. 10 mm ✓ □ Nat. Ret. 10 mm - ○ Lap. Ret. 6 mm - □ Nat. Ret. 6 mm - | - | ✓ | ✓ | ✓ | |
| | Nero Belvedere | ○ Lap. Ret. 10 mm ✓ ○ Lap. Ret. 6 mm - | - | ✓ | ✓ | ✓ | |
| | AESTHETICA | Hegel | ○ Lap. Ret. 10 mm ✓ ○ Lap. Ret. 6 mm - □ Nat. Ret. 10 mm - □ Nat. Ret. 6 mm - | ✓ | ✓ | ✓ | ✓ |
| | | Wilde | ○ Lap. Ret. 10 mm ✓ ○ Lap. Ret. 6 mm - □ Nat. Ret. 10 mm - □ Nat. Ret. 6 mm - | ✓ | ✓ | ✓ | ✓ |
| | | Princess | ○ Lap. Ret. 10 mm ✓ □ Nat. Ret. 10 mm - ○ Lap. Ret. 6 mm - □ Nat. Ret. 6 mm - | ✓ | ✓ | ✓ | ✓ |
| Duke | | ○ Lap. Ret. 10 mm ✓ □ Nat. Ret. 10 mm - ○ Lap. Ret. 6 mm - □ Nat. Ret. 6 mm - | ✓ | ✓ | ✓ | ✓ | |
| COPACABANA | Emperor | ○ Lap. Ret. 10 mm ✓ □ Nat. Ret. 10 mm - ○ Lap. Ret. 6 mm - □ Nat. Ret. 6 mm - | ✓ | ✓ | ✓ | ✓ | |
| | Ghiaccio | □ Nat. Ret. 10 mm ✓ ○ Lap. Ret. 10 mm - □ Nat. Ret. 6 mm - | ✓ | ✓ | ✓ | ✓ | |
| | Beige | □ Nat. Ret. 10 mm ✓ ○ Lap. Ret. 10 mm - □ Nat. Ret. 6 mm - | ✓ | ✓ | ✓ | ✓ | |
| SKYLINE | Fumo | □ Nat. Ret. 10 mm ✓ ○ Lap. Ret. 10 mm - □ Nat. Ret. 6 mm - | ✓ | ✓ | ✓ | ✓ | |
| | Antracite | □ Nat. Ret. 10 mm ✓ ○ Lap. Ret. 10 mm - □ Nat. Ret. 6 mm - | ✓ | ✓ | ✓ | ✓ | |
| | Bianco | □ Nat. Ret. 6 mm - | ✓ | ✓ | ✓ | ✓ | |
| DISTRICT | Grigio | □ Nat. Ret. 6 mm - | ✓ | ✓ | ✓ | ✓ | |
| | Tortora | □ Nat. Ret. 6 mm - | ✓ | ✓ | ✓ | ✓ | |
| | Nero | □ Nat. Ret. 6 mm - | ✓ | ✓ | ✓ | ✓ | |
| ABSOLUTE | White | □ Nat. Ret. 10 mm ✓ ○ Lap. Ret. 6 mm - □ Nat. Ret. 6 mm - | ✓ | ✓ | ✓ | ✓ | |
| | Black | □ Nat. Ret. 10 mm ✓ ○ Lap. Ret. 6 mm - □ Nat. Ret. 6 mm - | ✓ | ✓ | ✓ | ✓ | |

○ Lappato e rettificato. Lappato and rectified. Lappato et rectifié. Lappato und kalibriert. Lappato y rectificado. Ланплатированный ректифицированный. 亚光和抛光。
□ Naturale e rettificato. Natural and rectified. Naturel et rectifié. Natur Oberfläche und kalibriert. Natural y rectificado. Натуральный ректифицированный. 天然和抛光。

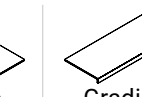
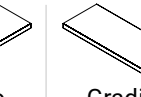
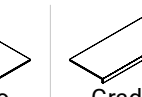
| | | |  |  |  |  |  |  |  |  |  |  |  |  |  |  |  |  |  |  |  | |
|----------------------|--|--|--|--|--|--|--|--|--|--|--|--|--|--|--|--|--|--|--|--|--|---|
| | | | Gradino Costa Retta 160x33x3,2h 63"x13"x1/4"h | Gradino Costa Retta 120x33x3,2h 48"x13"x1/4"h | Gradino Costa Retta 80x33x3,2h 31 1/2"x13"x1/4"h | Gradino Costa Retta Angolo DX 160x33x3,2h 63"x13"x1/4"h | Gradino Costa Retta Angolo SX 160x33x3,2h 63"x13"x1/4"h | Gradino Costa Retta Angolo DX 120x33x3,2h 48"x13"x1/4"h | Gradino Costa Retta Angolo SX 120x33x3,2h 48"x13"x1/4"h | Gradino Costa Retta Angolo DX 80x33x3,2 31 1/2"x13"x1/4"h | Gradino Costa Retta Angolo SX 80x33x3,2 31 1/2"x13"x1/4"h | Gradino Bordo Dritto 160x30x4h 63"x12"x1/2"h | Gradino Bordo Dritto 120x30x4h 48"x12"x1/2"h | Gradino Bordo Dritto 80x30x4h 31 1/2"x12"x1/2"h | Gradino Bordo Dritto Angolo DX 160x30x4h 63"x12"x1/2"h | Gradino Bordo Dritto Angolo SX 160x30x4h 63"x12"x1/2"h | Gradino Bordo Dritto Angolo DX 120x30x4h 48"x12"x1/2"h | Gradino Bordo Dritto Angolo SX 120x30x4h 48"x12"x1/2"h | Gradino Bordo Dritto Angolo DX 80x30x4h 31 1/2"x12"x1/2"h | Gradino Bordo Dritto Angolo SX 80x30x4h 31 1/2"x12"x1/2"h | | |
| I MARMI | Bianco Bernini | <input type="checkbox"/> Lap. Ret. 10 mm | - | ✓ | - | - | - | ✓ | ✓ | - | - | - | ✓ | ✓ | - | - | - | ✓ | ✓ | - | - | |
| | | <input type="checkbox"/> Nat. Ret. 10 mm | - | - | - | - | - | - | - | - | - | - | - | - | - | - | - | - | - | - | - | - |
| | | <input type="checkbox"/> Nat. Ret. 6 mm | ✓ | ✓ | ✓ | ✓ | ✓ | ✓ | ✓ | ✓ | ✓ | ✓ | ✓ | ✓ | ✓ | ✓ | ✓ | ✓ | ✓ | ✓ | ✓ | ✓ |
| | Calacatta | <input type="checkbox"/> Lap. Ret. 10 mm | - | ✓ | - | - | - | - | ✓ | ✓ | - | - | - | ✓ | ✓ | - | - | - | ✓ | ✓ | - | - |
| | | <input type="checkbox"/> Nat. Ret. 10 mm | - | - | - | - | - | - | - | - | - | - | - | - | - | - | - | - | - | - | - | - |
| | | <input type="checkbox"/> Nat. Ret. 6 mm | ✓ | ✓ | ✓ | ✓ | ✓ | ✓ | ✓ | ✓ | ✓ | ✓ | ✓ | ✓ | ✓ | ✓ | ✓ | ✓ | ✓ | ✓ | ✓ | ✓ |
| | Crema Marfil | <input type="checkbox"/> Lap. Ret. 10 mm | - | ✓ | - | - | - | - | ✓ | ✓ | - | - | - | ✓ | ✓ | - | - | - | ✓ | ✓ | - | - |
| | | <input type="checkbox"/> Nat. Ret. 10 mm | - | - | - | - | - | - | - | - | - | - | - | - | - | - | - | - | - | - | - | - |
| | | <input type="checkbox"/> Nat. Ret. 6 mm | ✓ | ✓ | ✓ | ✓ | ✓ | ✓ | ✓ | ✓ | ✓ | ✓ | ✓ | ✓ | ✓ | ✓ | ✓ | ✓ | ✓ | ✓ | ✓ | ✓ |
| | Statuario | <input type="checkbox"/> Lap. Ret. 10 mm | - | ✓ | - | - | - | - | ✓ | ✓ | - | - | - | ✓ | ✓ | - | - | - | ✓ | ✓ | - | - |
| | | <input type="checkbox"/> Nat. Ret. 10 mm | - | - | - | - | - | - | - | - | - | - | - | - | - | - | - | - | - | - | - | - |
| | | <input type="checkbox"/> Nat. Ret. 6 mm | ✓ | ✓ | ✓ | ✓ | ✓ | ✓ | ✓ | ✓ | ✓ | ✓ | ✓ | ✓ | ✓ | ✓ | ✓ | ✓ | ✓ | ✓ | ✓ | ✓ |
| Statuario Splendente | <input type="checkbox"/> Lap. Ret. 10 mm | - | ✓ | - | - | - | - | ✓ | ✓ | - | - | - | ✓ | ✓ | - | - | - | ✓ | ✓ | - | - | |
| | <input type="checkbox"/> Nat. Ret. 10 mm | - | - | - | - | - | - | - | - | - | - | - | - | - | - | - | - | - | - | - | - | |
| | <input type="checkbox"/> Nat. Ret. 6 mm | ✓ | ✓ | ✓ | ✓ | ✓ | ✓ | ✓ | ✓ | ✓ | ✓ | ✓ | ✓ | ✓ | ✓ | ✓ | ✓ | ✓ | ✓ | ✓ | ✓ | |
| Bardiglio | <input type="checkbox"/> Lap. Ret. 10 mm | - | ✓ | - | - | - | - | ✓ | ✓ | - | - | - | ✓ | ✓ | - | - | - | ✓ | ✓ | - | - | |
| | <input type="checkbox"/> Nat. Ret. 10 mm | - | - | - | - | - | - | - | - | - | - | - | - | - | - | - | - | - | - | - | - | |
| | <input type="checkbox"/> Nat. Ret. 6 mm | ✓ | ✓ | ✓ | ✓ | ✓ | ✓ | ✓ | ✓ | ✓ | ✓ | ✓ | ✓ | ✓ | ✓ | ✓ | ✓ | ✓ | ✓ | ✓ | ✓ | |
| Lasa | <input type="checkbox"/> Lap. Ret. 10 mm | - | ✓ | - | - | - | - | ✓ | ✓ | - | - | - | ✓ | ✓ | - | - | - | ✓ | ✓ | - | - | |
| | <input type="checkbox"/> Nat. Ret. 10 mm | - | - | - | - | - | - | - | - | - | - | - | - | - | - | - | - | - | - | - | - | |
| | <input type="checkbox"/> Nat. Ret. 6 mm | ✓ | ✓ | ✓ | ✓ | ✓ | ✓ | ✓ | ✓ | ✓ | ✓ | ✓ | ✓ | ✓ | ✓ | ✓ | ✓ | ✓ | ✓ | ✓ | ✓ | |
| Azul Macauba | <input type="checkbox"/> Lap. Ret. 10 mm | - | ✓ | - | - | - | - | ✓ | ✓ | - | - | - | ✓ | ✓ | - | - | - | ✓ | ✓ | - | - | |
| | <input type="checkbox"/> Nat. Ret. 10 mm | - | - | - | - | - | - | - | - | - | - | - | - | - | - | - | - | - | - | - | - | |
| | <input type="checkbox"/> Nat. Ret. 6 mm | ✓ | ✓ | ✓ | ✓ | ✓ | ✓ | ✓ | ✓ | ✓ | ✓ | ✓ | ✓ | ✓ | ✓ | ✓ | ✓ | ✓ | ✓ | ✓ | ✓ | |
| Nero Belvedere | <input type="checkbox"/> Lap. Ret. 10 mm | - | ✓ | - | - | - | - | ✓ | ✓ | - | - | - | ✓ | ✓ | - | - | - | ✓ | ✓ | - | - | |
| | <input type="checkbox"/> Nat. Ret. 10 mm | - | - | - | - | - | - | - | - | - | - | - | - | - | - | - | - | - | - | - | - | |
| | <input type="checkbox"/> Nat. Ret. 6 mm | ✓ | ✓ | ✓ | ✓ | ✓ | ✓ | ✓ | ✓ | ✓ | ✓ | ✓ | ✓ | ✓ | ✓ | ✓ | ✓ | ✓ | ✓ | ✓ | ✓ | |
| AESTHETICA | Hegel | <input type="checkbox"/> Lap. Ret. 10 mm | - | ✓ | - | - | - | ✓ | ✓ | - | - | - | ✓ | ✓ | - | - | - | ✓ | ✓ | - | - | |
| | | <input type="checkbox"/> Nat. Ret. 10 mm | - | - | - | - | - | - | - | - | - | - | - | - | - | - | - | - | - | - | - | |
| | | <input type="checkbox"/> Nat. Ret. 6 mm | ✓ | ✓ | ✓ | ✓ | ✓ | ✓ | ✓ | ✓ | ✓ | ✓ | ✓ | ✓ | ✓ | ✓ | ✓ | ✓ | ✓ | ✓ | ✓ | ✓ |
| Wilde | <input type="checkbox"/> Lap. Ret. 10 mm | - | ✓ | - | - | - | - | ✓ | ✓ | - | - | - | ✓ | ✓ | - | - | - | ✓ | ✓ | - | - | |
| | <input type="checkbox"/> Nat. Ret. 10 mm | - | - | - | - | - | - | - | - | - | - | - | - | - | - | - | - | - | - | - | - | |
| | <input type="checkbox"/> Nat. Ret. 6 mm | ✓ | ✓ | ✓ | ✓ | ✓ | ✓ | ✓ | ✓ | ✓ | ✓ | ✓ | ✓ | ✓ | ✓ | ✓ | ✓ | ✓ | ✓ | ✓ | ✓ | |
| COPACABANA | Princess | <input type="checkbox"/> Lap. Ret. 10 mm | - | ✓ | - | - | - | ✓ | ✓ | - | - | - | ✓ | ✓ | - | - | - | ✓ | ✓ | - | - | |
| | | <input type="checkbox"/> Nat. Ret. 10 mm | - | - | - | - | - | - | - | - | - | - | - | - | - | - | - | - | - | - | - | |
| | | <input type="checkbox"/> Nat. Ret. 6 mm | ✓ | ✓ | ✓ | ✓ | ✓ | ✓ | ✓ | ✓ | ✓ | ✓ | ✓ | ✓ | ✓ | ✓ | ✓ | ✓ | ✓ | ✓ | ✓ | ✓ |
| Duke | <input type="checkbox"/> Lap. Ret. 10 mm | - | ✓ | - | - | - | - | ✓ | ✓ | - | - | - | ✓ | ✓ | - | - | - | ✓ | ✓ | - | - | |
| | <input type="checkbox"/> Nat. Ret. 10 mm | - | - | - | - | - | - | - | - | - | - | - | - | - | - | - | - | - | - | - | - | |
| | <input type="checkbox"/> Nat. Ret. 6 mm | ✓ | ✓ | ✓ | ✓ | ✓ | ✓ | ✓ | ✓ | ✓ | ✓ | ✓ | ✓ | ✓ | ✓ | ✓ | ✓ | ✓ | ✓ | ✓ | ✓ | |
| Emperor | <input type="checkbox"/> Lap. Ret. 10 mm | - | ✓ | - | - | - | - | ✓ | ✓ | - | - | - | ✓ | ✓ | - | - | - | ✓ | ✓ | - | - | |
| | <input type="checkbox"/> Nat. Ret. 10 mm | - | - | - | - | - | - | - | - | - | - | - | - | - | - | - | - | - | - | - | - | |
| | <input type="checkbox"/> Nat. Ret. 6 mm | ✓ | ✓ | ✓ | ✓ | ✓ | ✓ | ✓ | ✓ | ✓ | ✓ | ✓ | ✓ | ✓ | ✓ | ✓ | ✓ | ✓ | ✓ | ✓ | ✓ | |
| SKYLINE | Ghiaccio | <input type="checkbox"/> Nat. Ret. 10 mm | - | ✓ | - | - | - | ✓ | ✓ | - | - | - | ✓ | ✓ | - | - | - | ✓ | ✓ | - | - | |
| | | <input type="checkbox"/> Lap. Ret. 10 mm | - | ✓ | - | - | - | - | ✓ | ✓ | - | - | - | ✓ | ✓ | - | - | - | ✓ | ✓ | - | - |
| | | <input type="checkbox"/> Nat. Ret. 6 mm | ✓ | ✓ | ✓ | ✓ | ✓ | ✓ | ✓ | ✓ | ✓ | ✓ | ✓ | ✓ | ✓ | ✓ | ✓ | ✓ | ✓ | ✓ | ✓ | ✓ |
| Beige | <input type="checkbox"/> Nat. Ret. 10 mm | - | ✓ | - | - | - | - | ✓ | ✓ | - | - | - | ✓ | ✓ | - | - | - | ✓ | ✓ | - | - | |
| | <input type="checkbox"/> Lap. Ret. 10 mm | - | ✓ | - | - | - | - | ✓ | ✓ | - | - | - | ✓ | ✓ | - | - | - | ✓ | ✓ | - | - | |
| | <input type="checkbox"/> Nat. Ret. 6 mm | ✓ | ✓ | ✓ | ✓ | ✓ | ✓ | ✓ | ✓ | ✓ | ✓ | ✓ | ✓ | ✓ | ✓ | ✓ | ✓ | ✓ | ✓ | ✓ | ✓ | |
| Fumo | <input type="checkbox"/> Nat. Ret. 10 mm | - | ✓ | - | - | - | - | ✓ | ✓ | - | - | - | ✓ | ✓ | - | - | - | ✓ | ✓ | - | - | |
| | <input type="checkbox"/> Lap. Ret. 10 mm | - | ✓ | - | - | - | - | ✓ | ✓ | - | - | - | ✓ | ✓ | - | - | - | ✓ | ✓ | - | - | |
| | <input type="checkbox"/> Nat. Ret. 6 mm | ✓ | ✓ | ✓ | ✓ | ✓ | ✓ | ✓ | ✓ | ✓ | ✓ | ✓ | ✓ | ✓ | ✓ | ✓ | ✓ | ✓ | ✓ | ✓ | ✓ | |
| Antracite | <input type="checkbox"/> Nat. Ret. 10 mm | - | ✓ | - | - | - | - | ✓ | ✓ | - | - | - | ✓ | ✓ | - | - | - | ✓ | ✓ | - | - | |
| | <input type="checkbox"/> Lap. Ret. 10 mm | - | ✓ | - | - | - | - | ✓ | ✓ | - | - | - | ✓ | ✓ | - | - | - | ✓ | ✓ | - | - | |
| | <input type="checkbox"/> Nat. Ret. 6 mm | ✓ | ✓ | ✓ | ✓ | ✓ | ✓ | ✓ | ✓ | ✓ | ✓ | ✓ | ✓ | ✓ | ✓ | ✓ | ✓ | ✓ | ✓ | ✓ | ✓ | |
| DISTRICT | Bianco | <input type="checkbox"/> Nat. Ret. 6 mm | ✓ | ✓ | ✓ | ✓ | ✓ | ✓ | ✓ | ✓ | ✓ | ✓ | ✓ | ✓ | ✓ | ✓ | ✓ | ✓ | ✓ | ✓ | ✓ | |
| | | <input type="checkbox"/> Nat. Ret. 6 mm | ✓ | ✓ | ✓ | ✓ | ✓ | ✓ | ✓ | ✓ | ✓ | ✓ | ✓ | ✓ | ✓ | ✓ | ✓ | ✓ | ✓ | ✓ | ✓ | |
| | | <input type="checkbox"/> Nat. Ret. 6 mm | ✓ | ✓ | ✓ | ✓ | ✓ | ✓ | ✓ | ✓ | ✓ | ✓ | ✓ | ✓ | ✓ | ✓ | ✓ | ✓ | ✓ | ✓ | ✓ | ✓ |
| ABSOLUTE | White | <input type="checkbox"/> Nat. Ret. 10 mm | - | ✓ | - | - | - | ✓ | ✓ | - | - | - | ✓ | ✓ | - | - | - | ✓ | ✓ | - | - | |
| | | <input type="checkbox"/> Lap. Ret. 6 mm | ✓ | ✓ | ✓ | ✓ | ✓ | ✓ | ✓ | ✓ | ✓ | ✓ | ✓ | ✓ | ✓ | ✓ | ✓ | ✓ | ✓ | ✓ | ✓ | ✓ |
| | | <input type="checkbox"/> Nat. Ret. 6 mm | ✓ | ✓ | ✓ | ✓ | ✓ | ✓ | ✓ | ✓ | ✓ | ✓ | ✓ | ✓ | ✓ | ✓ | ✓ | ✓ | ✓ | ✓ | ✓ | ✓ |
| Black | <input type="checkbox"/> Nat. Ret. 10 mm | - | ✓ | - | - | - | - | ✓ | ✓ | - | - | - | ✓ | ✓ | - | - | - | ✓ | ✓ | - | - | |
| | <input type="checkbox"/> Lap. Ret. 6 mm | ✓ | ✓ | ✓ | ✓ | ✓ | ✓ | ✓ | ✓ | ✓ | ✓ | ✓ | ✓ | ✓ | ✓ | ✓ | ✓ | ✓ | ✓ | ✓ | ✓ | |
| | <input type="checkbox"/> Nat. Ret. 6 mm | ✓ | ✓ | ✓ | ✓ | ✓ | ✓ | ✓ | ✓ | ✓ | ✓ | ✓ | ✓ | ✓ | ✓ | ✓ | ✓ | ✓ | ✓ | ✓ | ✓ | |

Per il gradino non si garantisce la stessa tonalità del fondo. We cannot guarantee that the shade of the stair tile will be the same as the background tile. Pour la marche, nous ne garantissons pas la même tonalité du fond. Für die Stufe wird nicht der gleiche Farbton des Untergrunds garantiert. Para el peldaño no se garantiza el mismo tono del fondo. Для ступени не гарантирована одинаковость тона с фоном. 对于台阶不保证底色一致

* A disposizione solo su richiesta. Tempi di consegna: 30gg. Available upon request only. Delivery terms: 30 days. Disponible seulement sur requête. Délais de livraison: 30 jours. Verfügbar auf Anfrage. Lieferzeit: 30 Tage. Disponible sólo bajo pedido. Plazo de entrega: 30 días. Изготавливается только по специальной заявке. Срок поставки: 30 дней. 仅依订购。交货时间: 30日。

○ Lappato e rettificato. Lappato and rectified. Lappato et rectifié. Lappato und kalibriert. Lappato y rectificado. Ланплатированный ректифицированный. 亚光和抛光。
 □ Naturale e rettificato. Natural and rectified. Naturel et rectifié. Natur Oberfläche und kalibriert. Natural y rectificado. Натуральный ректифицированный. 天然和抛光。

| FORMATO cm. Size | SPESSORE. Thickness | TIPOLOGIA IMBALLO. Type of packing | LASTRE Slabs | MQ LASTRA Sqm Slab | KG LASTRA Kg Slab | MQ. Sqm | KG Kg | TARA Tare |
|---------------------|------------------------|--|-----------------|-----------------------|----------------------|------------|----------|--------------|
| 160x320 | 6 mm | Cassa / Crate 345x175x37 | 14 | 5,12 | 74,14 | 71,68 | 1.178 | 140,00 |
| | | Cavalletto / A-Frame 330x75x193,5 | 44 | | | 225,28 | 3.472 | 210,00 |
| 160x160 | 6 mm | Cassa / Crate 182,6x173,6x40,4 | 24 | 2,56 | 37,07 | 61,44 | 962 | 71,80 |
| | | Cavalletto / A-Frame 330x75x193,5 | 88 | | | 225,28 | 3.472 | 210,00 |
| 120x240 | 6 mm | Cassa / Crate 264x136x40 | 20 | 2,88 | 41,70 | 57,60 | 934 | 100,00 |
| | | Cavalletto / A-Frame 250x75x153,5 | 44 | | | 126,72 | 1.993 | 158,00 |
| 120x120 | 6 mm | Cavalletto / A-Frame 250x75x153,5 | 88 | 1,44 | 20,85 | 126,72 | 1.993 | 158,00 |
| 80x240 | 6 mm | Cassa / Crate 265x96x47 | 30 | 1,92 | 27,80 | 57,60 | 912 | 78,00 |
| | | Cavalletto / A-Frame 250x75x153,5 | 44 | | | 84,48 | 1.381 | 158,00 |
| 80x160 | 6 mm | Pallet speciale con sponde Special pallet with sides 168x97x40,9 | 30 | 1,28 | 18,60 | 38,40 | 603 | 45,00 |

| FORMATO cm. Size | SPESSORE. Thickness | TIPOLOGIA IMBALLO. Type of packing | PZ. X SCAT. Pieces x Box | MQ. X SCAT. Sqm x Box | KG X SCAT. Weight x Box | SCAT. X PAL. Boxes x Pal. | MQ. X PAL. Sqm x Pal. | KG X PAL. Weight x Pal. |
|---------------------|------------------------|---|-----------------------------|--------------------------|----------------------------|------------------------------|--------------------------|----------------------------|
| 120x120 | 6 mm | Pallet speciale con sponde Special pallet with sides 143x123x64,7 | 2 | 2,88 | 41,70 | 24 | 69,12 | 1.057 |
| 80x80 | 6 mm | Europallet 80x120 | 3 | 1,92 | 27,90 | 40 | 76,80 | 1.141 |
| 60x120 | 10 mm | Europallet 80x120 | 2 | 1,44 | 33,41 | 30 | 43,20 | 1.025 |
| 60x60 | 10 mm | Europallet 80x120 | 3 | 1,08 | 24,80 | 40 | 43,20 | 1.012 |

I pesi riportati in tabella sono indicativi in quanto possono subire leggere variazioni per motivi produttivi. The weights stated in the chart are approximate as some changes may be necessary for production reasons. Les poids figurant dans le tableau sont fournis à titre indicatif car ils peuvent subir de légères variations pour des raisons de production. Die in der Tabelle aufgeführten Gewichte sind nicht bindend, da sie aus Produktionsgründen leichte Änderungen aufweisen können. Los pesos señalados en la tabla son aproximados ya que pueden experimentar ligeras variaciones por motivos productivos. Указанный в таблице вес является приблизительным, так как ввиду производственных потребностей, он может слегка измениться. 表格记载的重量只具有提示意义, 因为可能在生产过程中产生轻微的偏差。

CASSE
Crate



Formato Lastre / Size Slabs
160x320

CASSE
Crate



Formato Lastre / Size Slabs
120x240

CASSE
Crate



Formato Lastre / Size Slabs
80x240

CASSE
Crate



Formato Lastre / Size Slabs
160x160

CAVALLETTO
A-Frame



Formato Lastre / Size Slabs
160x320
160x160

CAVALLETTO
A-Frame



Formato Lastre / Size Slabs
120x240
120x120

PALLET SPONDE ALTE
High - Sided pallets



Formato Lastre / Size Slabs
120x120

PALLET SPONDE ALTE
High - Sided pallets



Formato Lastre / Size Slabs
80x160

CERTIFICAZIONI DI PRODOTTO

Product certification . Certification de produit . Produkt Zertifizierungen . Certificaciones de producto . Сертификация . 产品认证



CARATTERISTICHE TECNICHE

Technical features . Caracteristiques techniques . Technische Eigenschaften . Caracteristicas tecnicas . Технические характеристики . 技术特点

LASTRE IN GRES PORCELLANATO PRESSATE A SECCO. Classificazione secondo UNI EN 14411-ISO 13006 - G - Bla (E ≤ 0,5%) UGL

Dry-pressed porcelain stoneware slabs. Product in compliance with UNI EN 14411-ISO 13006 - G - Bla (E ≤ 0,5%) UGL.













Dalles en grès cérame pressées à sec. Classement selon UNI EN 14411-ISO 13006 - G - Bla (E ≤ 0,5%) UGL.

Trockengepresste Platten aus Feinsteinzeug. Klassifizierung nach UNI EN 14411-ISO 13006 - G - Bla (E ≤ 0,5%) UGL.

Planchas en gres porcelánico prensadas en seco. Clasificación según UNI EN 14411-ISO 13006 - G - Bla (E ≤ 0,5%) UGL.

Керамогранитные плиты сухого прессования. Классификация согласно европейской сертификации UNI EN 14411-ISO 13006 - G - Bla (E ≤ 0,5%) UGL.

干压机制瓷制砖. 根据UNI EN 14411-ISO 13006 - G - Bla (E ≤ 0,5%) UGL的分类

| | CARATTERISTICA Specification Caracteristique Eigenschaft Característica Характеристика 功能 | METODO DI PROVA Test methods Methode d'essai Testverfahren Prueba Стандарт испытаний 方法测试 | VALORE PRESCRITTO Fixed value Valeur prescrite Vorgeschriebener Wert Valor prescrito Требуемый значение 指引 |  |
|---|---|--|---|--|
|  | Caratteristiche dimensionali Dimensional characteristics - Dimensions Dimensionale Eigenschaften - Características dimensionales Пространственные характеристики - 尺寸特性 | ISO 10545-2 | | Conforme Compliant Conforme Erfüllt Cumple Соответствует 符合性 |
|  | Assorbimento d'acqua Water absorption - Absorption d'eau - Wasseraufnahme Absorción de agua - Водопоглощение - 吸水率 | ISO 10545-3 | ≤ 0,5 % | ≤ 0,05 % |
|  | Resistenza alla flessione Breaking modulus - Resistance a la flexion - Biegefestigkeit Resistencia a la flexión - прочность на изгиб - 弯曲强度 | | ≥ 35 N/mm ² | Conforme Compliant Conforme Erfüllt Cumple Соответствует 符合性 |
| | Sforzo di rottura Modulus of rupture - Charge de rupture - Bruchlast Esfuerzo de rotura - Стойкость на изгиб - 断裂应力 | ISO 10545-4 | ≥ 7,5 mm = ≥ 1300 N < 7,5 mm = ≥ 700 N | Conforme Compliant Conforme Erfüllt Cumple Соответствует 符合性 |
|  | Resistenza alla abrasione profonda Deep abrasion resistance - Resistance a l'abrasion profonde Beständigkeit gegen Tiefenverschleiß - 深层磨损耐性 | ISO 10545-6 | ≤ 175 mm ³ | < 175 mm ³ |
|  | Coefficiente di dilatazione termica lineare Thermal expansion coefficient - Coefficient de dilatation thermique lineaire Wärmeausdehnungskoeffizient - Coefficiente de dilatación térmica lineal коэффициент теплового линейного расширения - 线性热膨胀系数 | ISO 10545-8 | Metodo disponibile Available on request - Methode disponible Verfügbares Verfahren - Método disponible Определяется производителем - 可行方法 | ≤ 7x10 ⁻⁶ °C ⁻¹ |
|  | Resistenza agli sbalzi termici Thermal shock resistance - Resistance aux écarts de temperature Temperaturwechselbeständigkeit - Resistencia a choque térmico Устойчивость к температурным перепадам - 抗热震性 | ISO 10545-9 | Metodo disponibile Available on request - Methode disponible Verfügbares Verfahren - Método disponible Определяется производителем - 可行方法 | Resistenti Resistant Résistants Widerstandsfähig Resiste устойчивы 耐性 |
|  | Resistenza al gelo Frost resistance - Resistance au gel - Frostbeständigkeit Resistencia al hielo - Морозостойкость - 抗冻性 | ISO 10545-12 | Richiesta Always tested - Exigee - Notwendig - Pedido требования - 申请 | Resistenti Resistant Résistants Widerstandsfähig Resiste устойчивы 耐性 |
|  | Resistenza ai prodotti chimici Chemical resistance - Resistance aux produits chimiques Chemische Beständigkeit - Resistencia a los productos quimicos Химическая устойчивость - 耐化学腐蚀 | ISO 10545-13 | min. UB | Resistenti Resistant Résistants Widerstandsfähig Resiste устойчивы 耐性 |
| | Prodotti chimici ad uso domestico ed additivi per piscina Household chemicals and swimming pool water cleansers Produits chimiques courants et additifs pour piscine Chem.Produkte für den Haushaltsgebrauch und Zusatz für Schwimmbäder Productos químicos para uso doméstico y con aditivos para piscina бытовые химические средства и средства для бассейнов - 家用化学产品和游泳池添加剂 | | | |
| | Acidi ed alcali a bassa concentrazione Acids and low concentration alkalis - Acides et alcali a faible concentration Säuren und Alkali in geringer Konzentration - Ácidos y álcalis en baja concentración Низкоконцентрированные кислоты и щёлочи - 低浓度下酸碱性 | | | |
|  | Resistenza alle macchie Stain resistance - Resistance aux taches - Fleckbeständigkeit Resistencia a las manchas - Устойчивость к загрязнению - 耐沾污 | ISO 10545-14 | Metodo disponibile Available on request - Methode disponible Verfügbares Verfahren - Método disponible Определяется производителем - 可行方法 | min. 4 |
|  | Stabilità dei colori alla luce Colour stability to light - Stabilité des couleurs a la lumiere - Lichtechtheit der Farben Estabilidad de los colores - Устойчивость цвета - 光无色牢度 | DIN 51094 | Metodo disponibile Available on request - Methode disponible Verfügbares Verfahren - Método disponible Определяется производителем - 可行方法 | Conforme Compliant Conforme Erfüllt Cumple Соответствует 符合性 |
|  | Coefficiente di attrito (scivolosità) Friction coefficient (slipperiness) | ANSI A 137.1:2012 | ≥ 0,42 | ≥ 0,42 Superficie naturale Natural surface |

Art direction
LA FABBRICA S.p.A.

Progetto grafico
OMNIADVERT

Stampa
INTESE GRAFICHE

Thanks to
RAIMONDI S.p.A.
Attrezzature per il taglio delle lastre

La Fabbrica S.p.A. si riserva di apportare, senza alcun preavviso, le modifiche che riterrà più opportune al fine di migliorare il prodotto. Quanto riportato è da considerarsi indicativo e non esaustivo in riferimento ai colori e alle caratteristiche estetiche dei prodotti.

LA FABBRICA S.p.A. reserves the right to make any changes it deems fit in order to improve the product, without prior notice. All images are provided for illustrative purposes only and other colours and aesthetic features are available.



3

La Fabbrica S.p.A.

Via Emilia Ponente, 925
48014 Castel Bolognese (RA) Italy
Tel. +39 0546 - 659911
Fax +39 0546 - 656223
www.avaceramica.it
www.lafabbrica.it

DAFIN GROUP

| | | |
|---|---|---|
|  www.avaceramica.it |  www.lafabbrica.it |  www.iblspa.it |
|---|---|---|

Follow us

